

Features

HIGH CURRENT CARRY AND HIGH VOLTAGE

Inert gas filled arc chamber suitable for high voltage switching

COMPACT STRUCTURE, LOW NOISE

Small, low-profile design with low noise while carrying or switching loads

COIL ECONOMIZER

Economized coil for low power consumption

SAFE FOR EXPLOSIVE ENVIRONMENTS

No arc leakage due to a hermetically sealed design

HIGH RELIABILITY DESIGN

Hermetic sealing creates a stable environment for high voltage switching

NO SPECIFIC MOUNTING ARRANGEMENT

Mountable in any orientation without reduction of performance

VARIOUS APPLICATIONS

Battery disconnect, EV charging, energy storage systems, photovoltaics, power control, circuit protection and much more

Sealing Type: Epoxy Resin

- ✓ Internal coil economizer option
- ✓ Bidirectional switching option
- ✓ High voltage switching options



Certification Information

1. Meet RoHS (2011/65/EU)
2. UL Approved
3. CE Certified

Nomenclature

AEV250

M

A

H

Series code:

“AEV250” = AEV250

Coil Voltage Code:

“M” = 12 - 24 VDC

“F” = 72 VDC

“G” = 48 - 72 VDC

Options:

Blank = Std. Options (Bottom Mount, Without Aux. Contact & Polarized Load Terminals)

“A” = With Aux. Contact (SPST-NO)

“B” = With Aux. Contact (SPST-NC)

“N” = Non-Polar Load Terminals

“P” = Potted PCB (Cannot be used with either NO or NC Aux)

“E” = Without Coil Economizer (External Coil Economizer Required)

“H” = 1000 Volts Switching Voltage

Note: The non-polar “N” series devices operate at 1000VDC, rendering the 'H' designation obsolete when paired with “N”. Also, the 'H' version is incompatible with the potted PCB and external PWM configurations.



Performance Data for 900V Switching Option

MAIN CONTACT

Contact Arrangement	1 Form X (SPST-NO)	
Max. Switching Voltage	900VDC	
Continuous (Carry) Current	500 (85°C Ambient)	
Max Short Circuit Current	7000A @450v (3ms)	
Dielectric Withstanding Voltage (initial)	Between Open Contacts	4000VAC (leakage <1mA)
	Between Contacts to Coil	2200Vrms (leakage <1mA)
Insulation Resistance (initial)	Terminal to Terminal	New: Min 100 MΩ @500VDC End of life: Min 50 MΩ@500VDC
	Terminals to Coil	
Voltage Drop	<30mV @100A	

OPERATE / RELEASE TIME

Close (includes bounce)	25ms, Max.
Release (@2000A includes arc)	12ms, Max

ENVIRONMENTAL DATA

Shock	Functional	196m/s ² Sine half-wave pulse
	Destructive	490m/s ² Sine half-wave pulse
Vibration, Sine, Peak, 20G		80 to 2,000Hz
Operating Temperature		-40 to +85°C
Altitude		<4000m
Weight		0.95 Lb (0.43 kg)

MAKE/BREAK LIFE CAPACITIVE & RESISTIVE LOADS AT 320VDC*1

@90% pre-charge (make only)	50,000 cycles
@Min 80% pre-charge (make only)	50 cycles

AUX CONTACT

Aux. Contact Arrangement	1 Form A, 1 Form B
Aux. Contact Current Max	2A@30VDC / 3A@125VAC
Aux. Contact Current Min	1mA@5V
Aux. Contact Resistance Max	0.417ohms@30VDC/ 0.150ohms@125VAC

COIL DATA

Coil Voltage	12-24VDC	48-72VDC	72VDC
Voltage (Max.)	36VDC	95VDC	95VDC
Max. Pick-up Voltage	9VDC	32VDC	48VDC
Min. Drop-out Voltage	6VDC	18VDC	27VDC
Max. Inrush Current	3.8A	1.3A	0.7A
Avg. Holding Current	0.13A@12VDC / 0.07A@24VDC	0.03A@ 48VDC	0.02A@ 72VDC
Nominal Power	1.8W	1.5W	1.5W



Performance Data for AEV250-XX-H /1000V Switching Option

MAIN CONTACT

Contact Arrangement	1 Form X (SPST-NO)	
Max. Switching Voltage	1000 VDC	
Rated Current	500A	
Max. Short Circuit Current	7000A @450v (3ms)	
Dielectric Withstanding Voltage (initial)	Between Open Contacts	4000VDC 1mA 1min
	Between Contacts to Coil	2200VAC 1mA 1min
Insulation Resistance (initial)	Terminal to Terminal	Min 1000 M Ω @1000VDC
	Terminals to Coil	
Voltage Drop	<30mV @100A	
Limit breaking	2000A@450VDC, 1 Cycle	

OPERATE / RELEASE TIME

Close (includes bounce)	25ms, Max.@20°C
Release Time	12ms, Max.@ 20 °C

ENVIRONMENTAL DATA

Shock	Functional	196m/s ² Sine half-wave pulse
	Destructive	490m/s ² Sine half-wave pulse
Vibration, Sine, Peak, 20G		80 to 2,000Hz
Operating Temperature		-40 to +85°C
Altitude		<4000m
Weight		0.43kg
Humidity		5% to 85%RH

EXPECTED LIFE

Electrical Endurance	50A @1000V 6000 cycles make/break 250 @1000V 1000 cycles break only
Mechanical Life	200,000 Cycle

AUX CONTACT

Aux. Contact Arrangement	1 Form A
Aux. Contact Current Max	2A@30VDC/3A@125VAC
Aux. Contact Current Min	1mA@5V
Aux. Contact Resistance Max.	0.417ohms@30VDC/ 0.150ohms@125VAC

COIL DATA

Coil Voltage	12-24VDC	48-72VDC	72VDC
Voltage (Max.)	36VDC	95VDC	95VDC
Max. Pick-up Voltage	9VDC	32VDC	48VDC
Min. Drop-out Voltage	6VDC	18VDC	27VDC
Max. Inrush Current	3.8A	1.3A	0.7A
Avg. Holding Current	0.13A@12VDC / 0.07A@24VDC	0.03A@ 48VDC	0.02A@ 72VDC
Nominal Power	1.8W	1.5W	1.5W

Performance Data

Current Carry vs Time (85°C Ambient)

500A Max (400 MCM) / 350A Max (2/0)

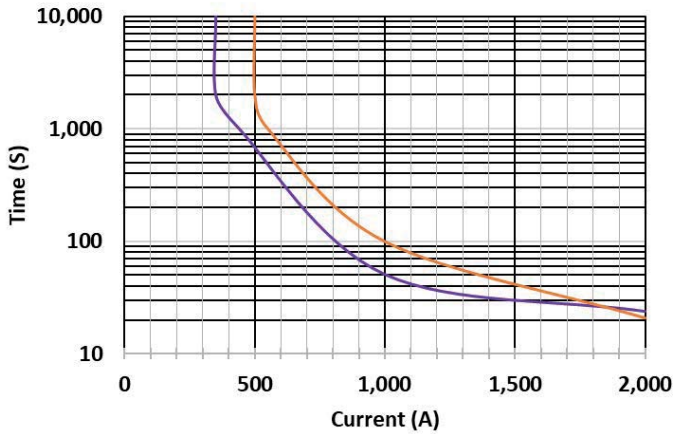

Capacitive Make Test Curves
 for Pre-Charged Motor Controller

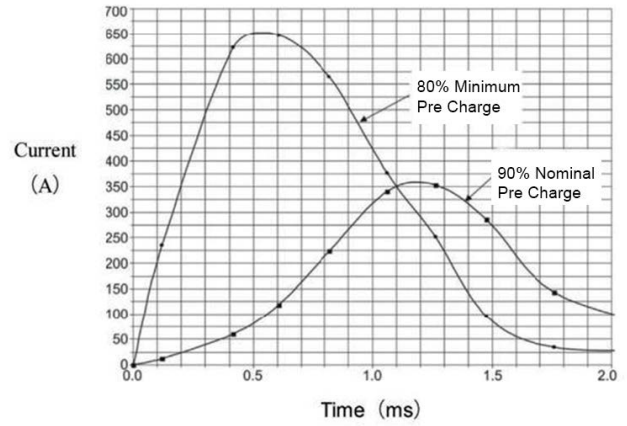

Estimated Make & Break Resistive Load Ratings for Polarized Type

900V Option

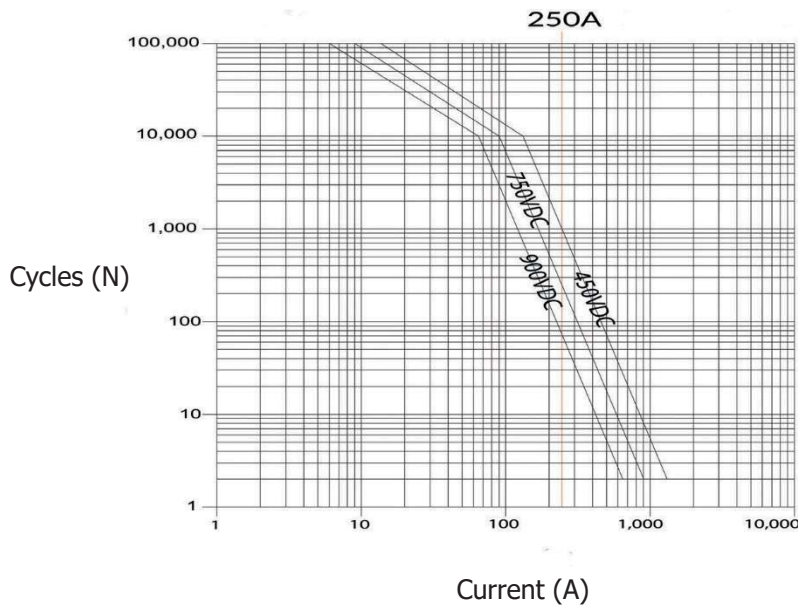

* Note:
 Estimates based on extrapolated data. User is encouraged to confirm performance in application.

Outline Dimensions (mm):

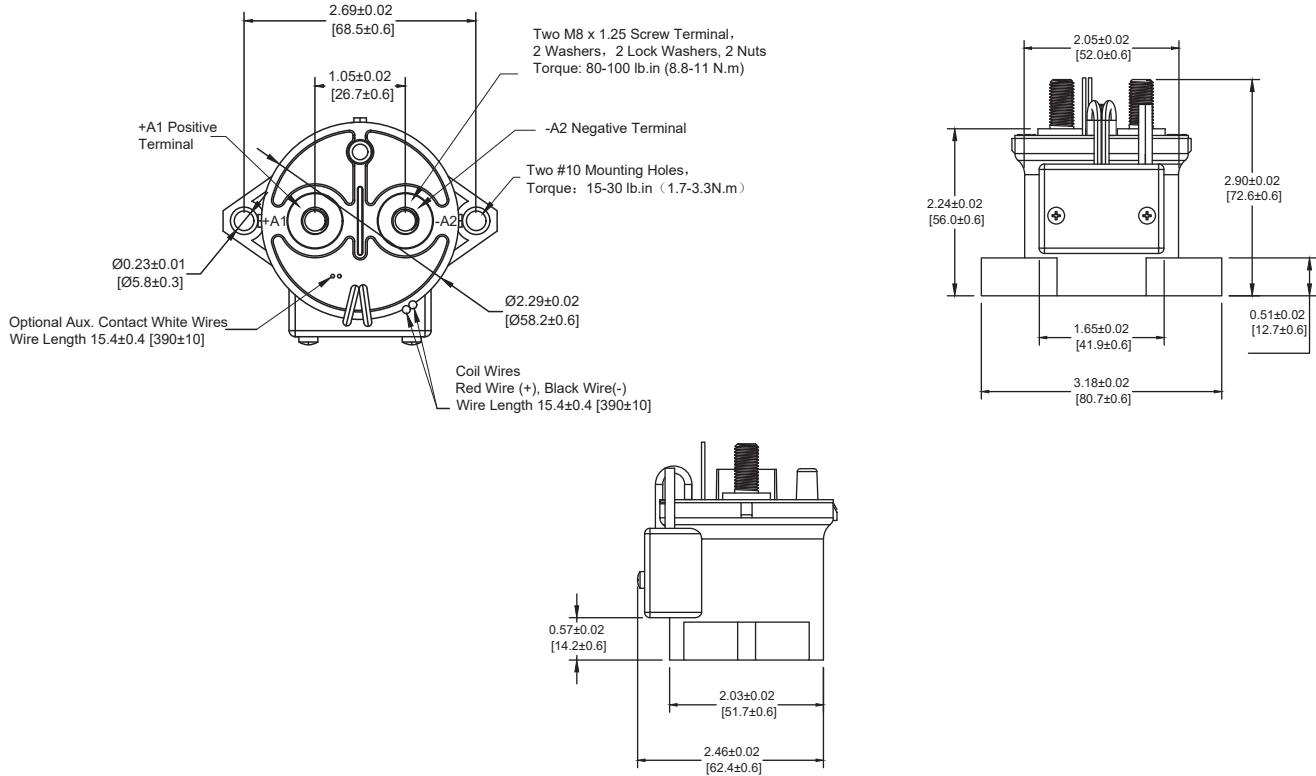

Potted PCB/Without Coil Economizer

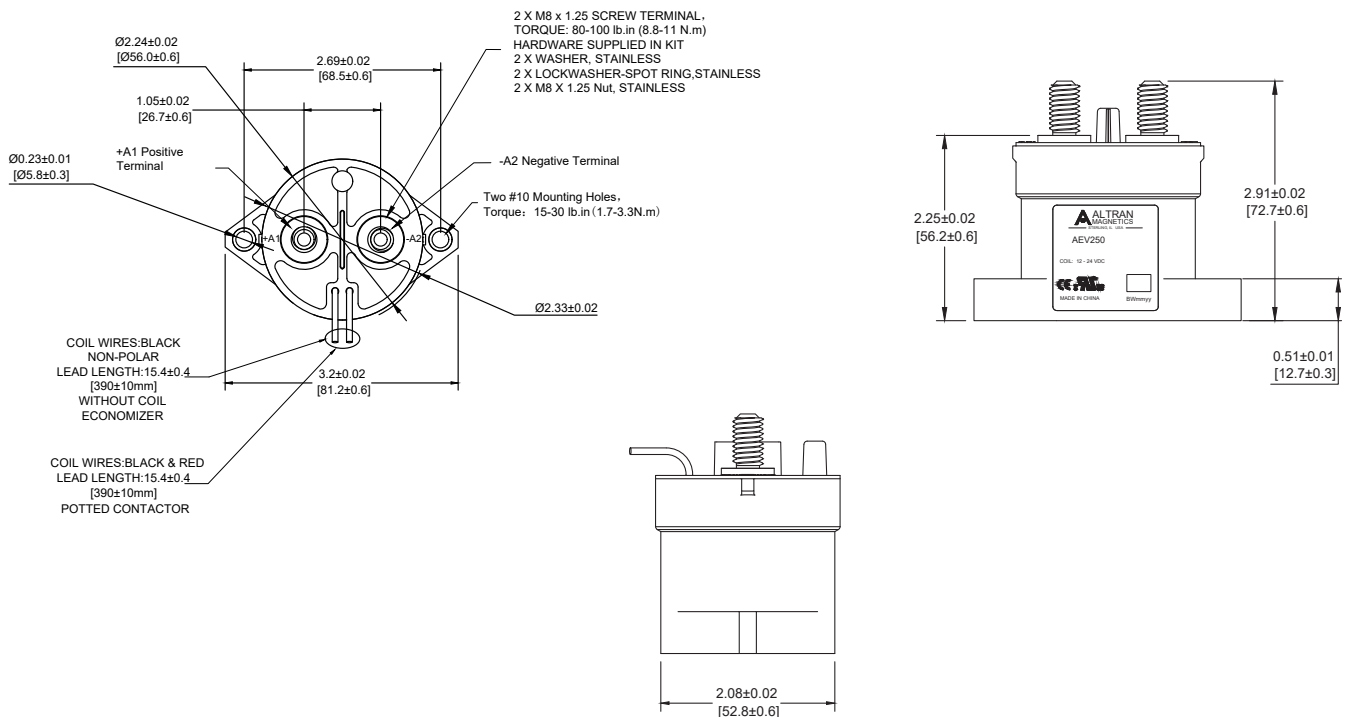

*Note: The wire size is 22 AWG.

Product Data Sheet

Non-polar

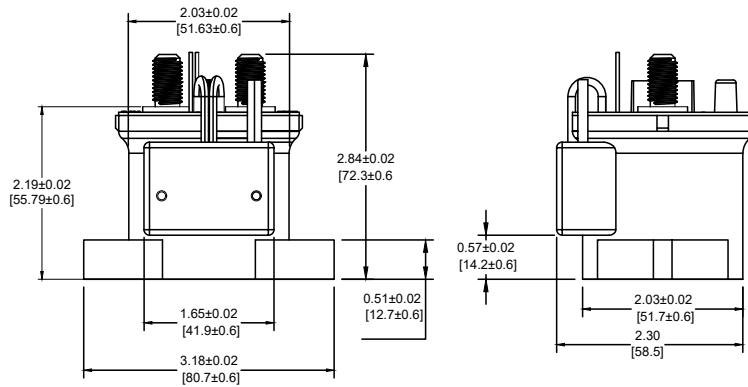
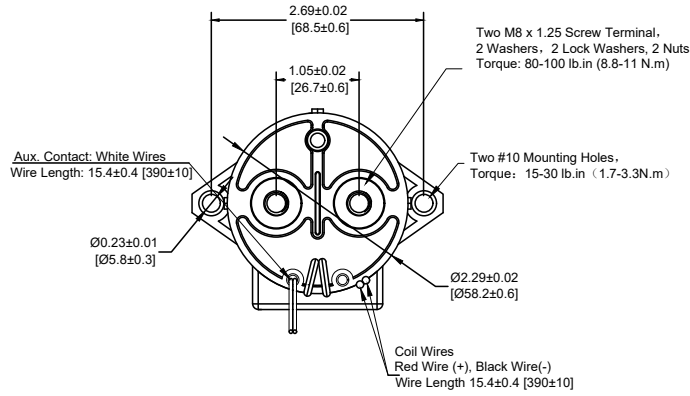

Normally Closed Aux Contacts

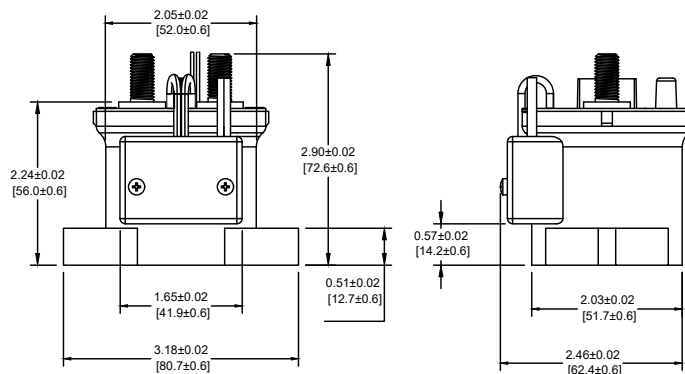
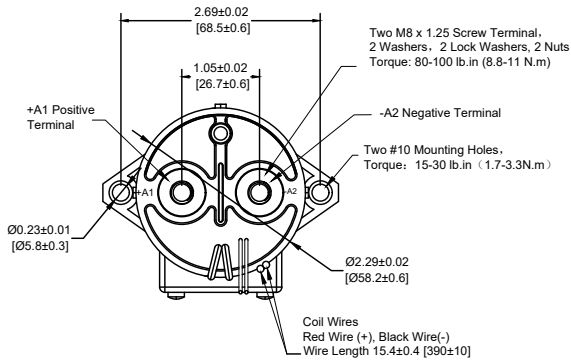

*Note: The wire size is 22 AWG.

Application Notes

1. To prevent loosening, split washers should be used whenever the contactor is installed. All terminals or conductors must be in direct contact with the contactor's main terminals. Please control the tightening torque of each part within the specified range in the table below. If the torque exceeds the recommended range, it may cause damage to the sealed cavity and thread damage.
 - Contact torque: (M8) 80-100 lb. in. (8.8 - 11 N.m)
 - Mounting torque: 15 - 30 lb. in. (1.7 - 3.3 N.m) Max.
2. Products with a coil economizer are already equipped with back EMF circuits, so there is no need to use surge protectors.
3. Avoid installing the contactor in a strong magnetic field environment (near transformers or magnets) and avoid placing the contactor near objects with heat radiation.
4. When continuous current is applied to the contacts of the relay, and the coil is turned on immediately after the power is cut off. At this time, as the temperature of the coil increases, the resistance of the coil will also increase, which will increase the pull-in voltage of the product, which may result in exceeding the rated pull-in voltage. In this case, the following measures should be taken to reduce the load current; limit the continuous power-on time or use a coil voltage higher than the rated pull-in voltage.
5. When the voltage is applied to products with a coil economizer, the circuit will automatically switch to the holding voltage about 100ms later. Please do not repeat the on-off operation during this time period, or the coil economizer of the contactor may be damaged.
6. When the voltage applied to the coil exceeds the maximum allowable applied voltage, the coil temperature may rise and lead to coil damage and interlayer short circuit.
7. The rated values in the contact parameters are values for resistive load. When using an inductive load with $L / R > 1\text{ms}$. please connect a surge current protection device to the inductive load in parallel. If no measures are taken, the electrical life may be reduced and the continuity may be poor. Please consider sufficient margin space in the design.
8. Coil drive power must be greater than coil power or it will reduce performance capability.
9. Please do not allow debris and oil to adhere to the main terminals; make sure that the main terminals are in reliable contact with the load conductor, otherwise the temperature rise of the terminal / conductor connection may be too high due to the excessive contact resistance.
10. The load conductor must have the corresponding current load capacity and heat dissipation capacity (it is recommended to use a copper bar with min 50mm²), to prevent overheating and affecting the life of the contactor.
11. It is impossible to determine the performance parameters of contactors in each specific application, therefore, customers should choose the products according to their own conditions of use. If in doubt, contact Altran. The customer will be responsible for validating that the products meet their application.
12. Do not use if dropped.
13. Altran reserves the right to make product changes as needed. Customers should reconfirm the contents of the specification or ask for us to supply a new specification if necessary.