

Features

- Compact Design
- Rated up to 1000A
- Low leakage versions available
- Chassis Mounting

Applications

- IT power Distribution Network
- Renewable Energy Systems
- Process Automation Equipments
- Energy Conversion Devices

Typical Circuit Diagram

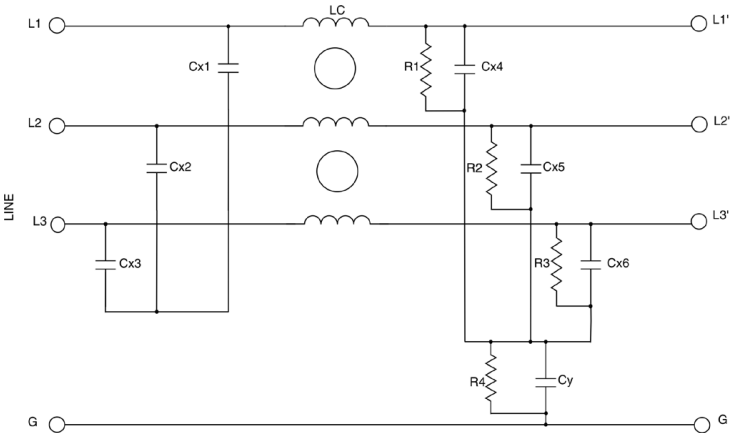

Approvals & Compliances



Technical Specifications

Maximum Continuous Operating Voltage	750VAC / 760VAC
Operating Frequency	50/60Hz
Current ratings	6A to 1000A @40°C
High Potential test voltage	L to G 3535VDC for 1 Minute L to L 3268VDC for 1 Minute
Overload Capability	135% of Rated current for 15 minutes
Design Corresponding to	UL 60939-3 and CSA 22.2 No 8-13
Flammability corresponding to	UL 94 V-0
Temperature range	-25°C to +85°C
Climatic Category	25/85/21

Selection Table

Available Part Number	Rated Current @40°C	Leakage current (mA)	Termination	Weight (Grams)
AMI-3367HV-6-16	6A	4	16	4
AMI-3367HV-10-16	10A	4	16	4
AMI-3367HV-16-16	16A	4	16	4
AMI-3367HV-20-16	20A	4	16	4
AMI-3367HV-25-16	25A	4	16	4.5
AMI-3367HV-30-16	30A	4	16	4.5
AMI-3367HV-40-16	40A	4	16	4.5
AMI-3367HV-50-16	50A	5	16	6
AMI-3367HV-60-16	60A	6	16	6
AMI-3367HV-75-16	75A	6	16	8
AMI-3367HV-80-16	80A	6	16	8
AMI-3367HV-90-25	90A	6	25	9
AMI-3367HV-100-25	100A	6	25	10
AMI-3367HV-125-M10	125A	6	M10 Stud	12
AMI-3367HV-150-M12	150A	6	M12 Stud	16.5
AMI-3367HV-180-M12	180A	6	M12 Stud	16.5
AMI-3367HV-250-M12	250A	6	M12 Stud	21
AMI-3367HV-300-BB	300A	6	Busbar - 6 x 25mm	11
AMI-3367HV-400-BB	400A	6	Busbar - 6 x 25mm	11
AMI-3367HV-500-BB	500A	6	Busbar -10 x 25mm	12
AMI-3367HV-600-BB	600A	6	Busbar -10 x 25mm	12
AMI-3367HV-700-BB	700A	6	Busbar -10 x 40mm	19
AMI-3367HV-800-BB	800A	6	Busbar -10 x 40mm	19
AMI-3367HV-1000-BB	1000A	6	Busbar -10 x 40mm	19

Connector Details

	16	25
Wire Section-Flexible (mm ²)	0.5-16mm ²	10-25mm ²
Recommended Torque	2-2.3 Nm	4-4.5 Nm

Screw Details

Thread Size	M10	M12
Recommended Torque (Nm)	15-17	27-28

Mechanical Drawing

6A-40A

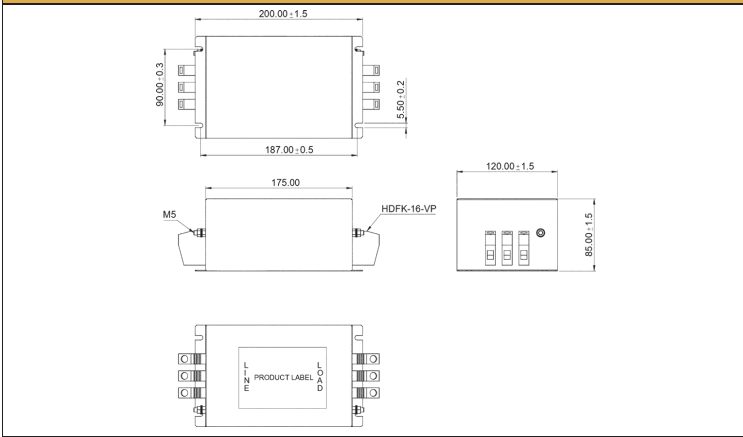

50A-80A

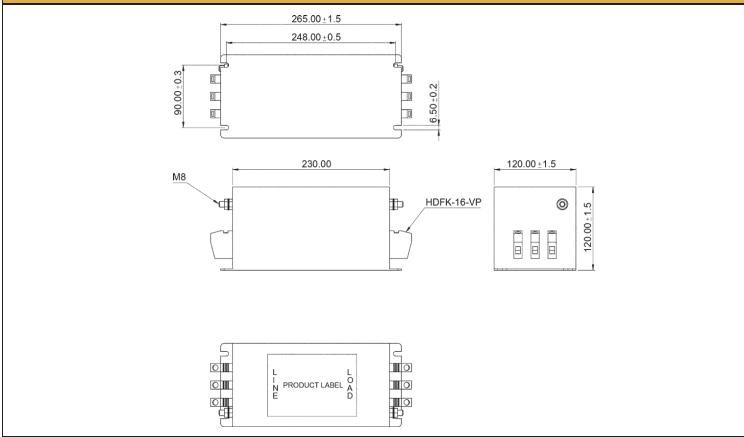

90A

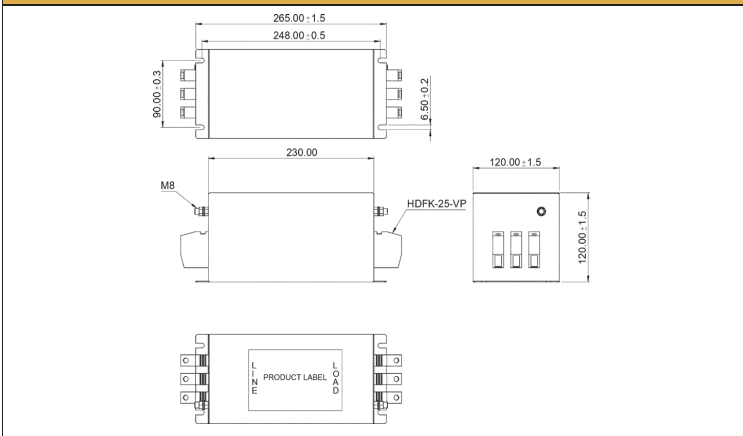

100A

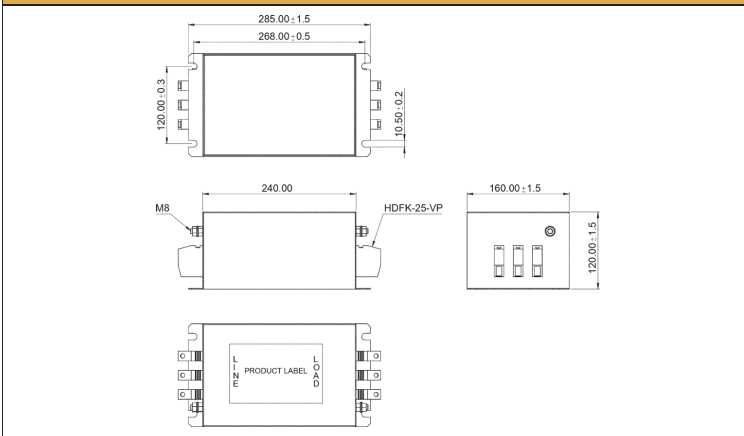

125A

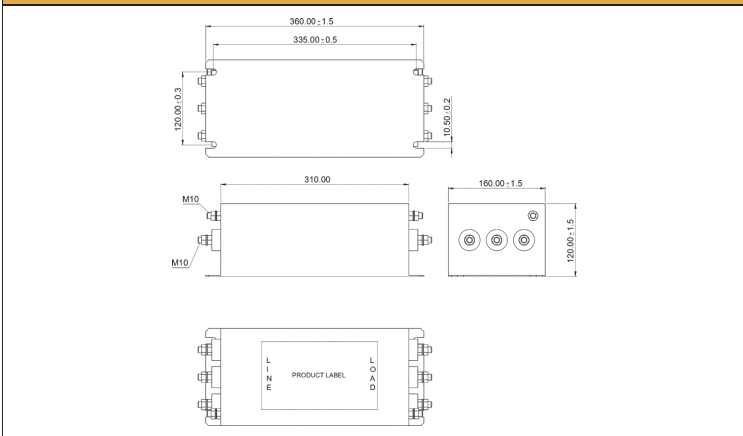

150A-250A

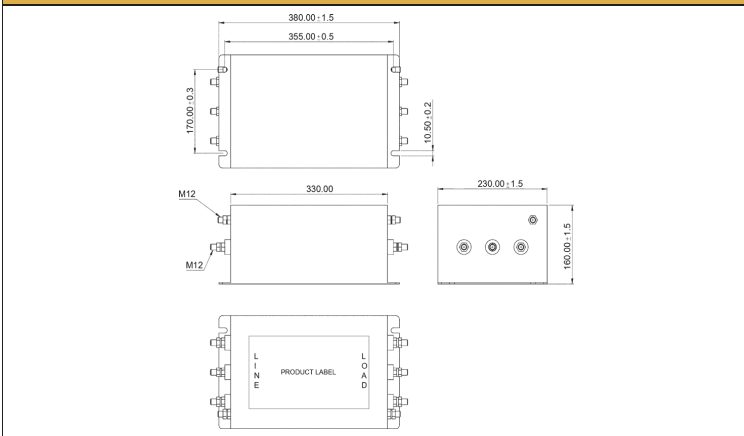

Mechanical Drawing

300A-400A

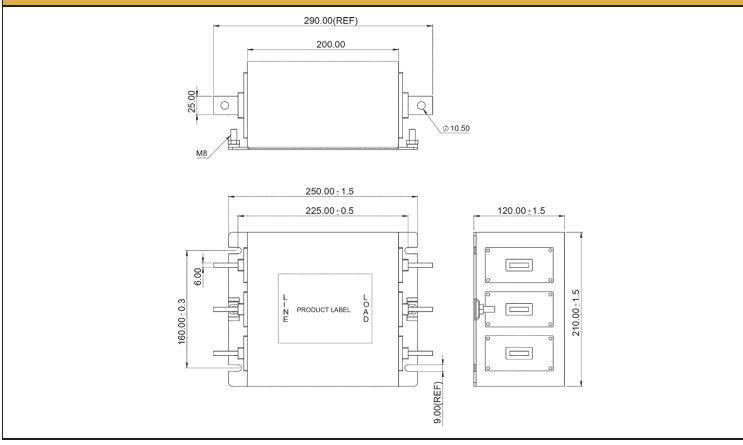

500A-600A

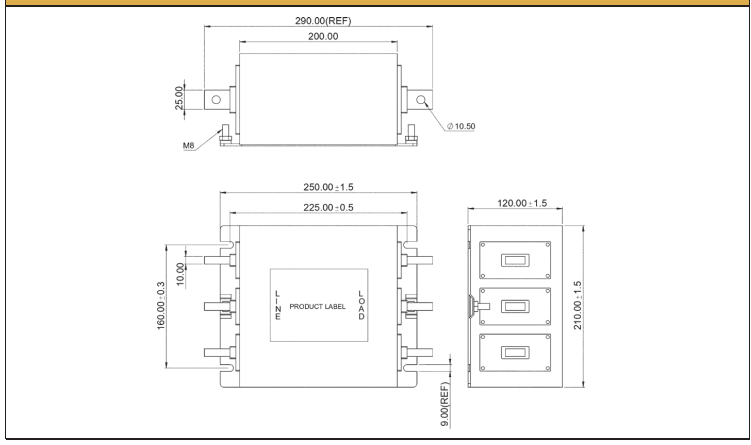

700-1000A

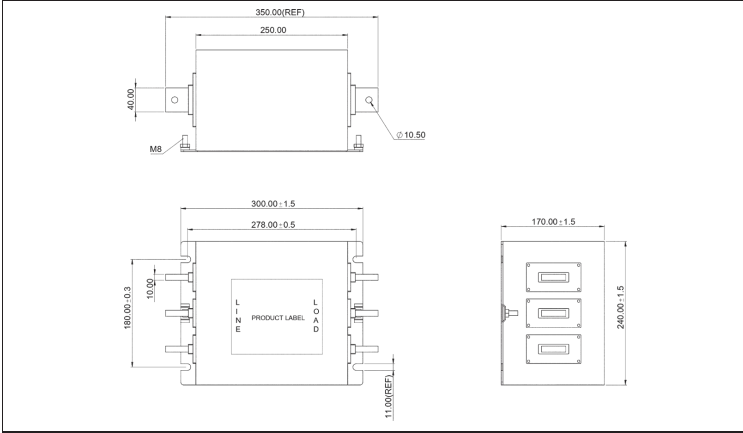

Typical Insertion Loss

According to CISPR17 in 50 Ω system

— Common Mode / Asymmetrical (L-G)
 — Differential Mode / Symmetrical (L-L)

16A

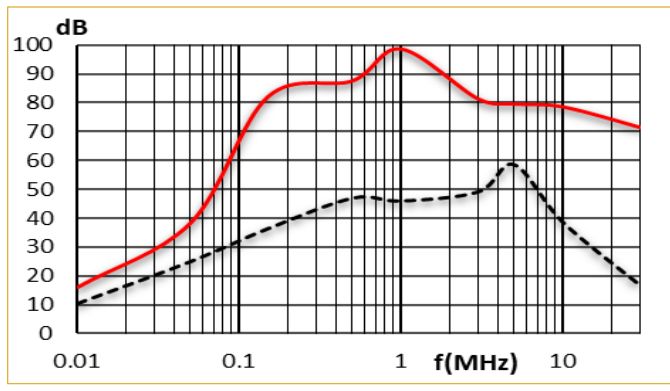

20A

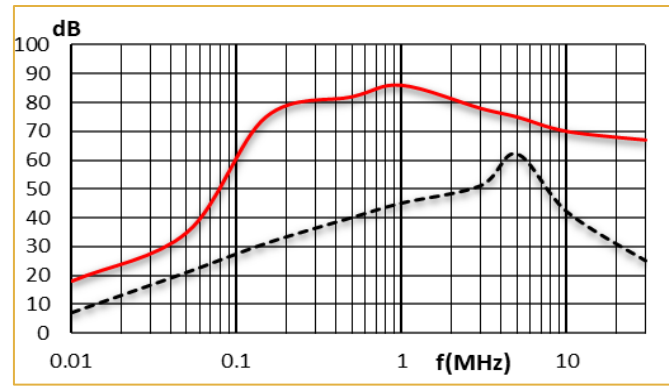

16A

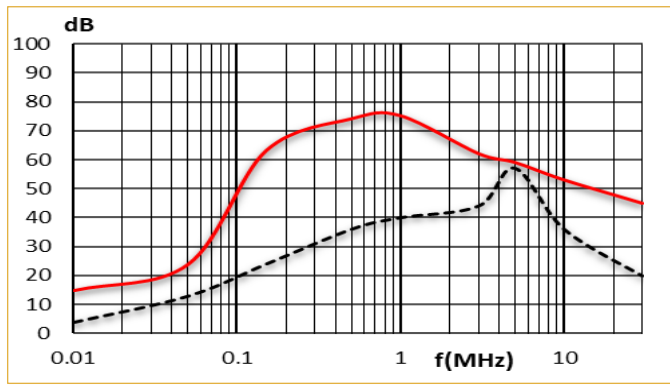

20A

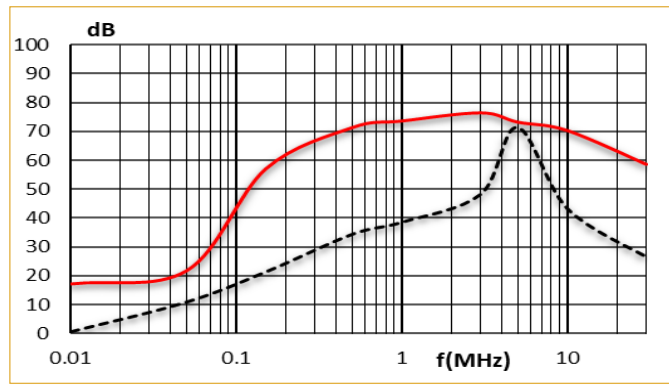

25A

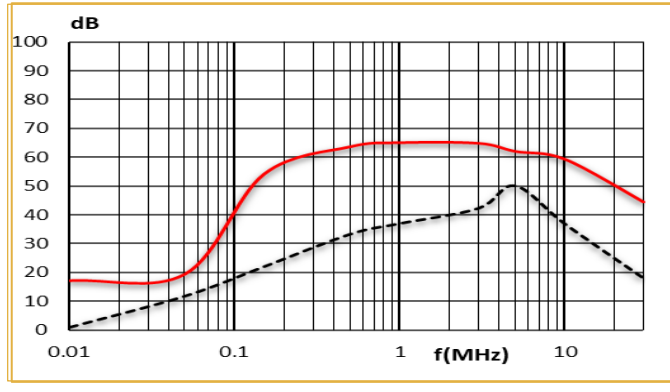

30A

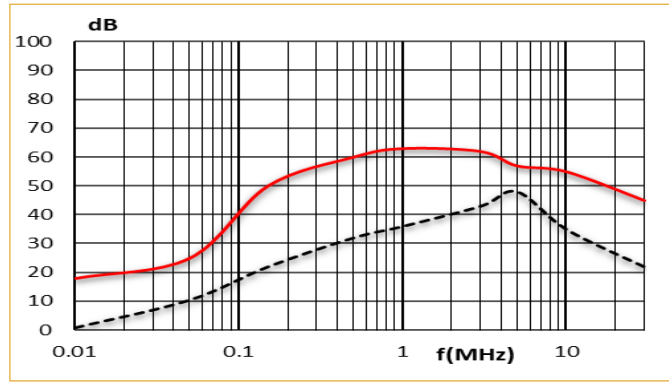

Typical Insertion Loss

According to CISPR17 in 50 Ω system

— Common Mode / Asymmetrical (L-G)
 — Differential Mode / Symmetrical (L-L)

40A

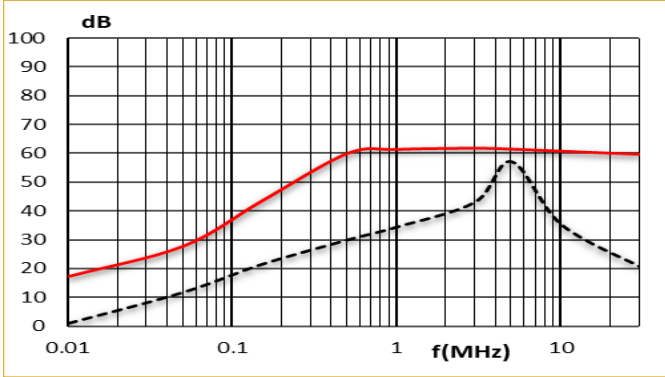

50A

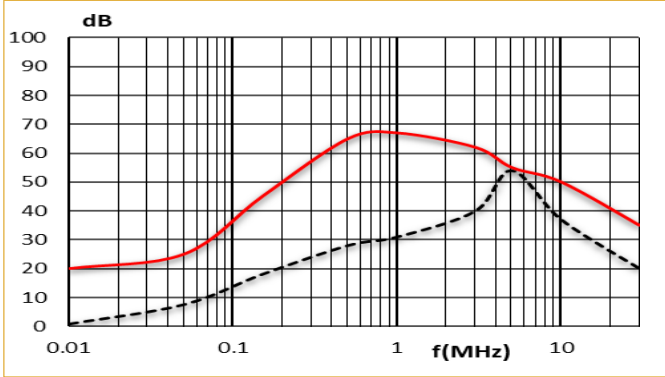

60A

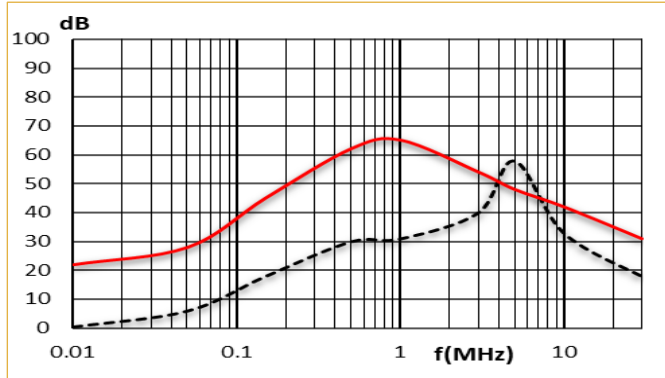

75A

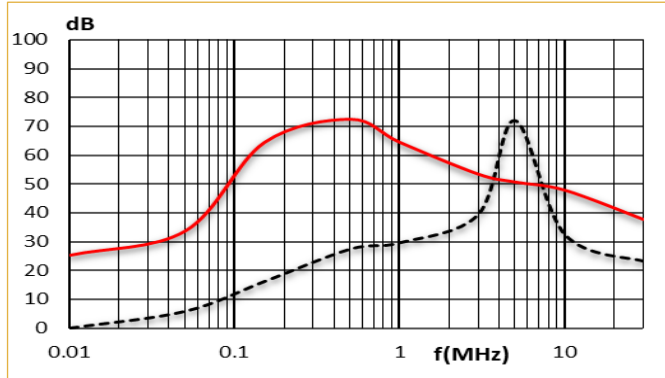

80A

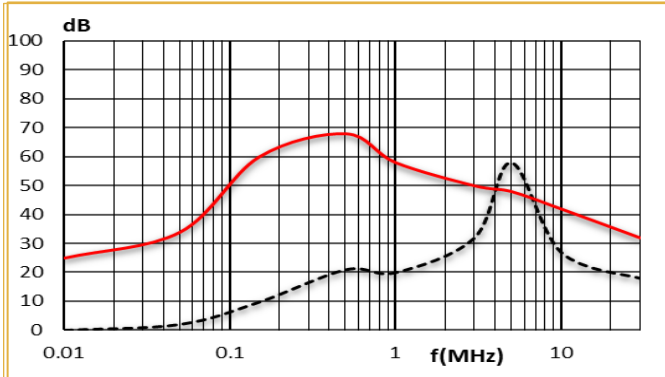

90A

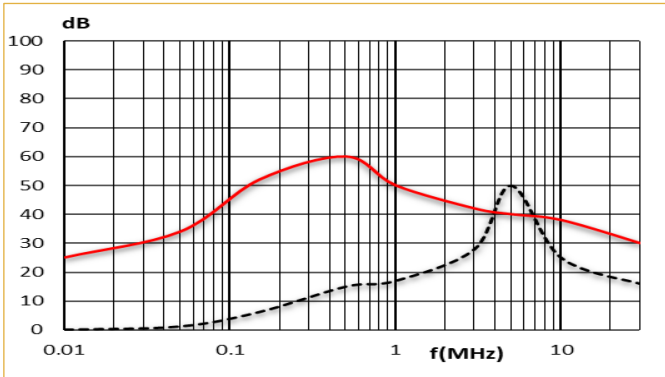

Typical Insertion Loss

According to CISPR17 in 50 Ω system

— Common Mode / Asymmetrical (L-G)
 — Differential Mode / Symmetrical (L-L)

100A

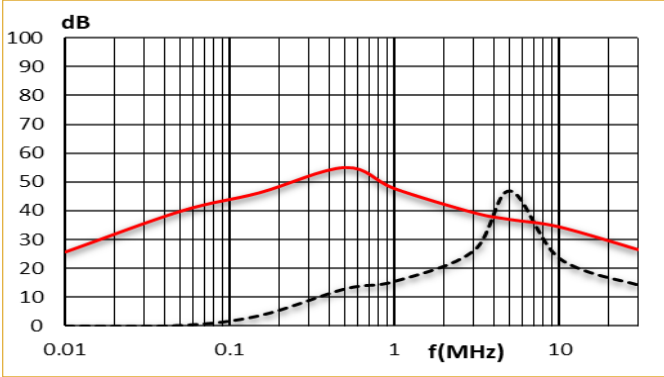

125A

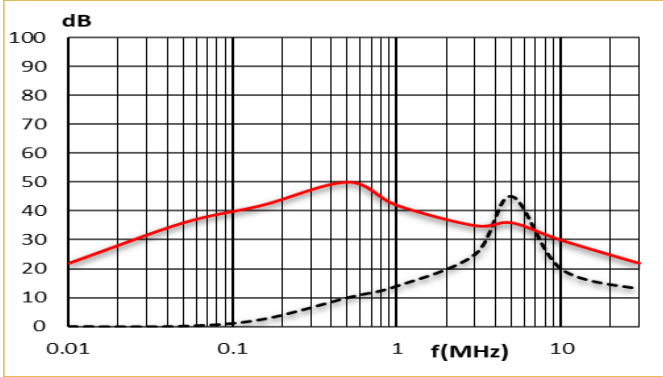

150A

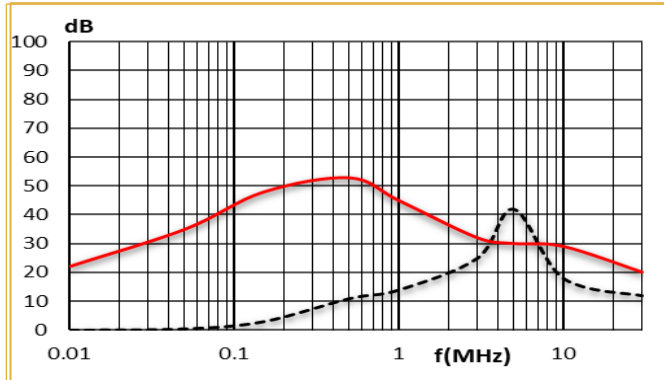

180A

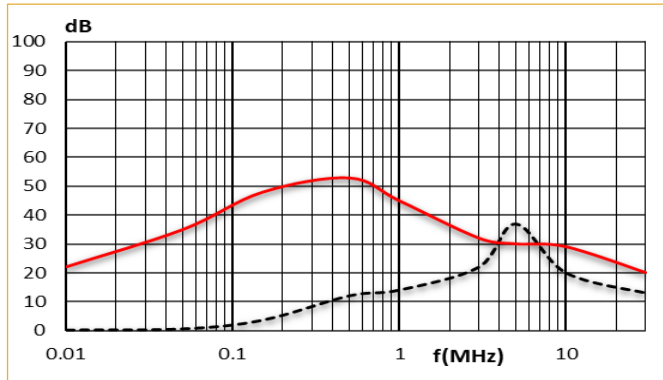

250A

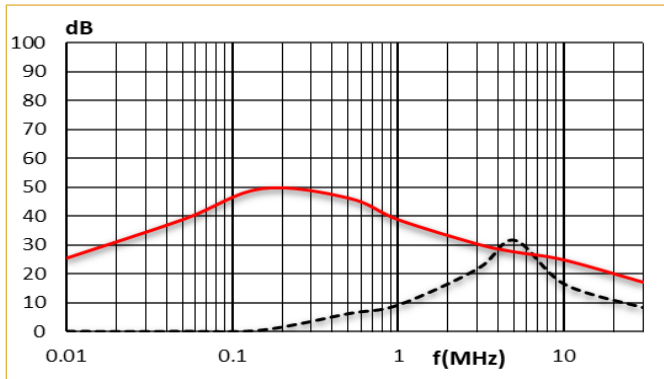

300A

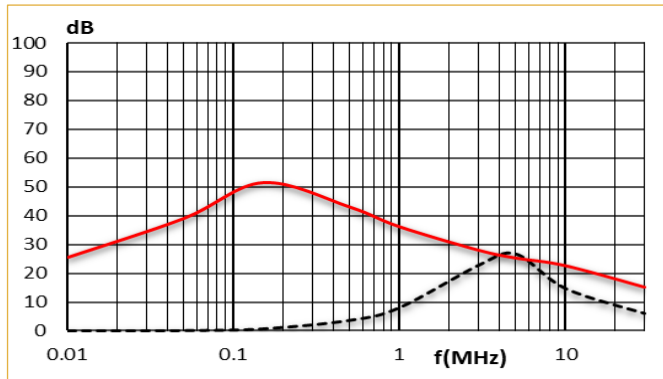

Typical Insertion Loss

According to CISPR17 in 50 Ω system

— Common Mode / Asymmetrical (L-G)
 — Differential Mode / Symmetrical (L-L)

400A

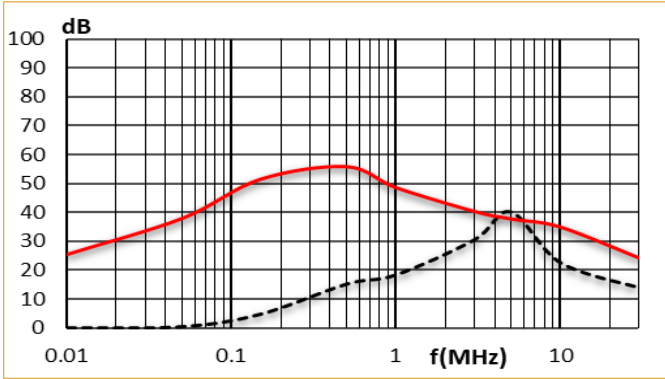

500A

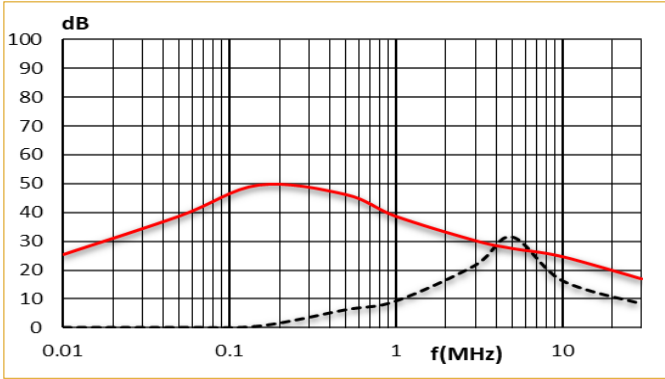

600A

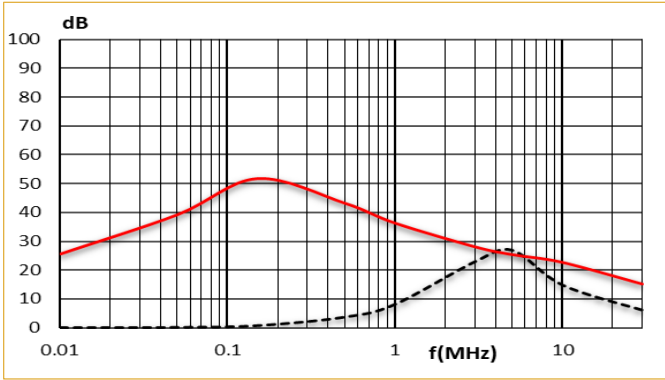

700A

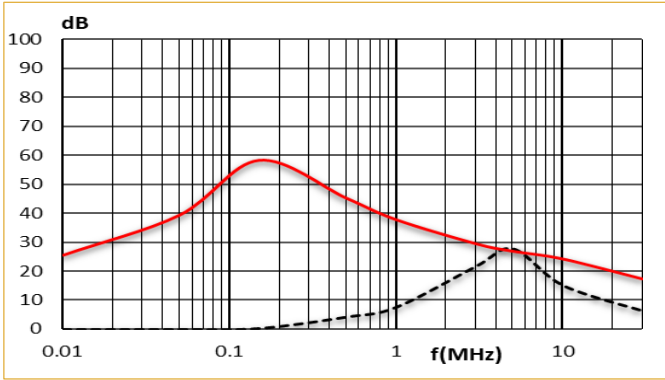

800A

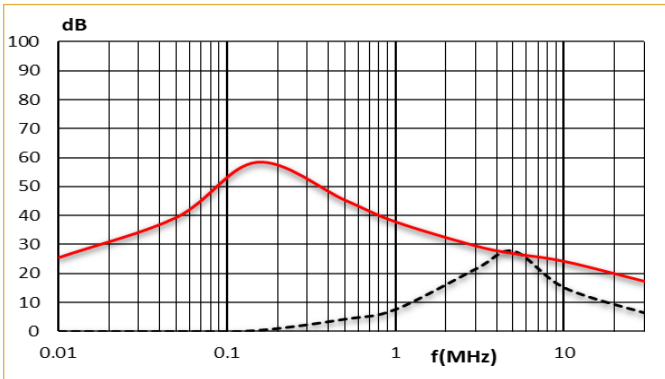

1000A

