

### Features

- General purpose filtering
- Rated up to 2500A
- Bus bar terminals
- Available with protective cover

### Applications

- Electrical and Electronic equipment
- AC/DC Drives
- Converters

### Typical Circuit Diagram

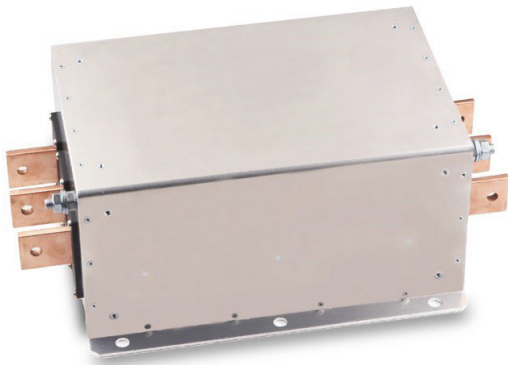
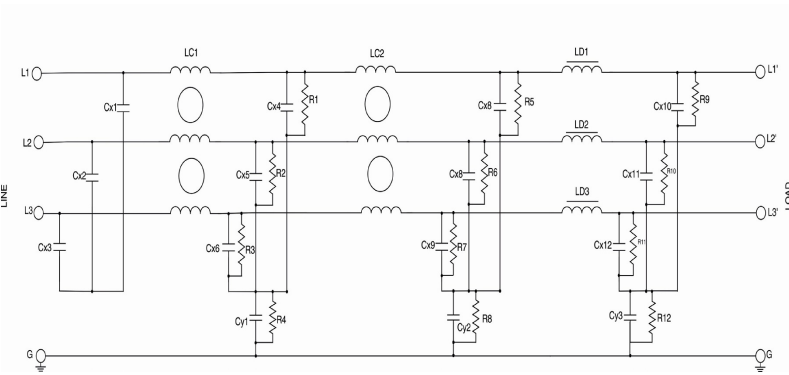



### Approvals & Compliances





### Technical Specifications

Maximum continuous operating voltage:	520VAC (AMI-3059) 760VAC (AMI-3059HV)
Operating Frequency:	DC to 60 Hz
Rated Currents:	150A to 2500A @ 50°C
High Potential test voltage:	L-> G 2856 VDC for 2 sec (AMI-3059) L-> 2236 VDC for 2 sec (AMI-3059) L-> G 3528 VDC for 2 sec (AMI-3059HV) L-> L 3268 VDC for 2 sec (AMI-3059HV)
Overload Capability:	4x rated current at switch on, 135% of rated current for 15Mins
Flammability corresponding to:	UL 94 V-0 or better
Temperature range:	-25°C to +100°C
Design corresponding to:	25/100/21
Design corresponding to:	UL 60939-3 & IEC 60939-1&2
Protection category:	IP 00

## Selection Table

Standard Performance						
Available Part Numbers	Current Rating @ 50°C (A)	Leakage current @ 520 VAC/ 50 Hz (mA)	Power loss 50Hz (W)	Termination		Weight Approx. (Kg)
						
AMI-3059-150-M10	150	5.5	25	M10	-	6
AMI-3059-180-M10	180	5.5	35	M10	-	6
AMI-3059-250-M10	250	5.5	50	M10	-	10
AMI-3059-320-BB	320	5.5	20	-	BB	11
AMI-3059-400-BB	400	5.5	30	-	BB	11
AMI-3059-600-BB	600	5.5	45	-	BB	13
AMI-3059-800-BB	800	6	40	-	BB	20
AMI-3059-1000-BB	1000	6	60	-	BB	20
AMI-3059-1600-BB	1600	5.5	135	-	BB	30
AMI-3059-2500-BB	2500	5.5	300	-	BB	70

High voltage versions						
Available Part Numbers	Current Rating @ 50°C (A)	Leakage current @ 520 VAC/ 50 Hz (mA)	Power loss 50Hz (W)	Termination		Weight Approx. (Kg)
						
AMI-3059HV-150-M10	150	7.5	25	M10	-	6
AMI-3059HV-180-M10	180	7.5	35	M10	-	6
AMI-3059HV-250-M10	250	7.5	50	M10	-	10
AMI-3059HV-320-BB	320	7.5	20	-	BB	11
AMI-3059HV-400-BB	400	7.5	30	-	BB	11
AMI-3059HV-600-BB	600	7.5	45	-	BB	13
AMI-3059HV-800-BB	800	7.5	40	-	BB	20
AMI-3059HV-1000-BB	1000	7.5	60	-	BB	20
AMI-3059HV-1600-BB	1600	7.5	135	-	BB	30
AMI-3059HV-2500-BB	2500	8	300	-	BB	70

## Mechanical Drawing

150A to 250A Types

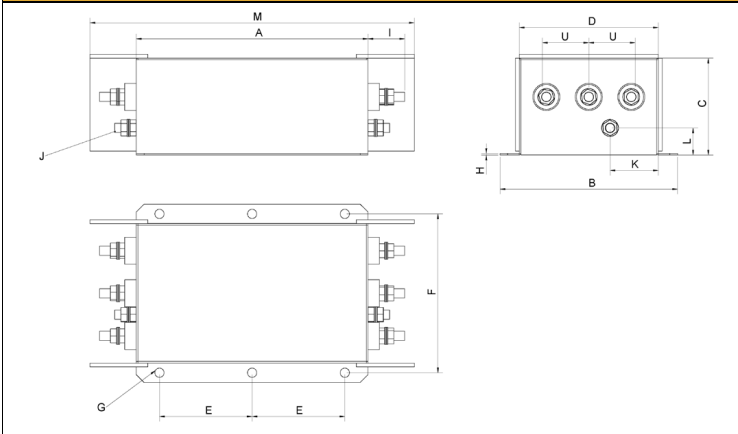

320A to 2500A Types

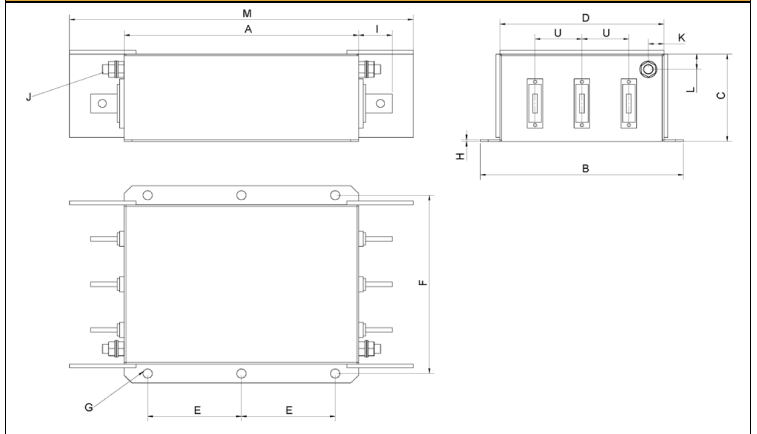

320 to 1000A

1600A Types

2500A Types

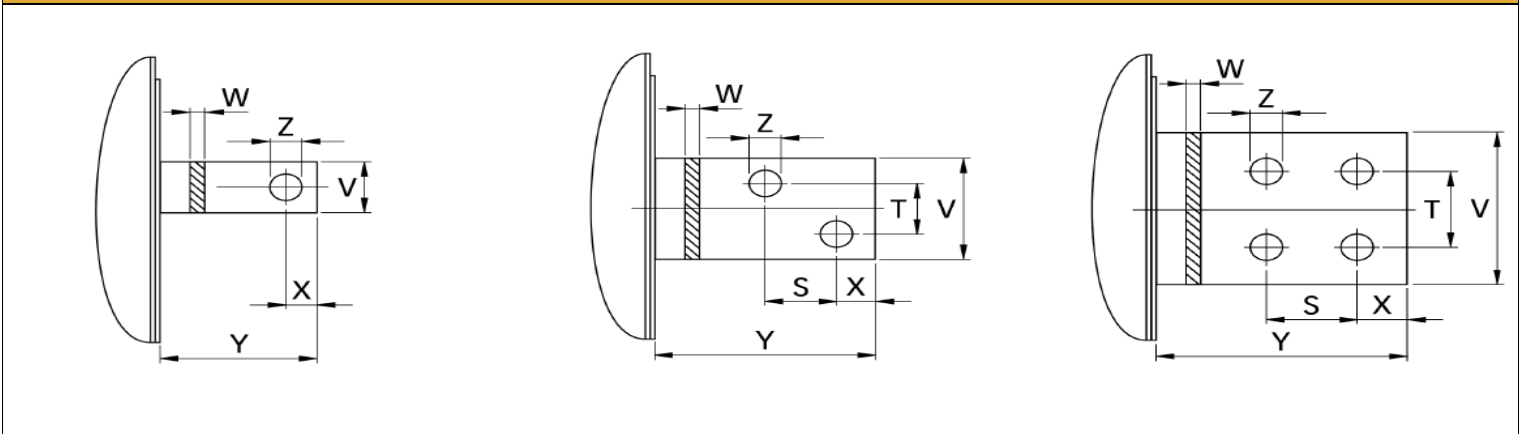

## Mechanical Dimensions:

	150A	180A	250A	320A	400A	600A	800A	1000A	1600A	2500A
A	300	300	300	300	300	300	350	350	400	450
B	210	210	230	260	260	260	280	280	300	370
C	120	120	125	115	115	135	170	170	160	220
D	160	160	180	210	210	210	230	230	250	300
E	120	120	120	120	120	120	145	145	170	200
F	185	185	205	235	235	235	255	255	275	330
G	φ12	φ12	φ12	φ12	φ12	φ12	φ12	φ12	φ12	φ14
H	2	2	2	2	2	2	3	3	3	3
I	33	33	33	43	43	43	53	53	93	110
J	M10	M10	M10	M12	M12	M12	M12	M12	M12	M12
K	55	55	62.5	20	20	20	25	25	25	25
L	30	30	35	20	20	20	25	25	25	25
M	420	420	420	440	440	440	510	510	-	-
U	50	50	55	60	60	60	60	60	60	100
V	-	-	-	25	25	25	40	40	60	80
W	-	-	-	6	6	8	8	8	10	15
X	-	-	-	15	15	15	20	20	17	20
Y	-	-	-	40	40	40	50	50	93	110
Z	-	-	-	φ10.5	φ10.5	φ10.5	φ14	φ14	φ14	φ14

All Dimensions in mm: 1 inch=25.4mm. Tolerance according : ISO 2768-C

## Typical Insertion Loss

According to CISPR17 in 50 Ω system

— Common Mode / Asymmetrical (L-G)  
— Differential Mode / Symmetrical (L-L)

150A to 180A Types

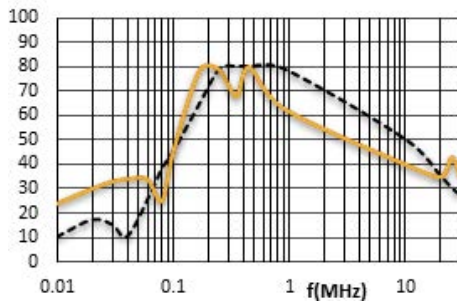

250A to 600A Types

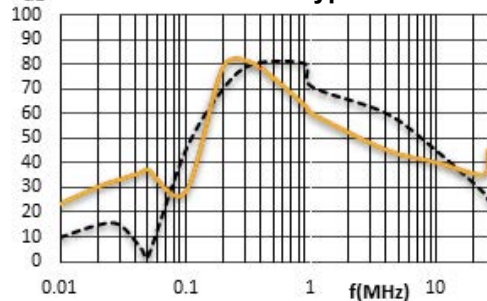

800A to 1000A Type

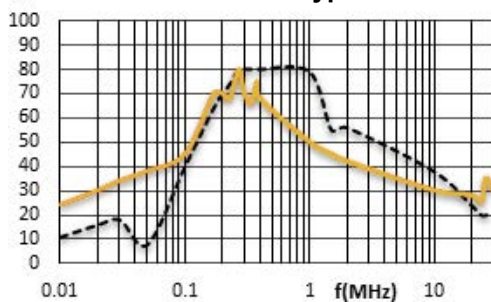

1600A to 2500A Types

