

Features

- High conducted attenuation
- Rated up to 30A
- One stage filters designed for noisy application requiring excellent filter performance
- Designed for easy and fast chassis mounting

Applications

- UPS/Inverters
- Electronic Equipment
- Medical equipment
- Electronic data processing equipment

Typical Circuit Diagram

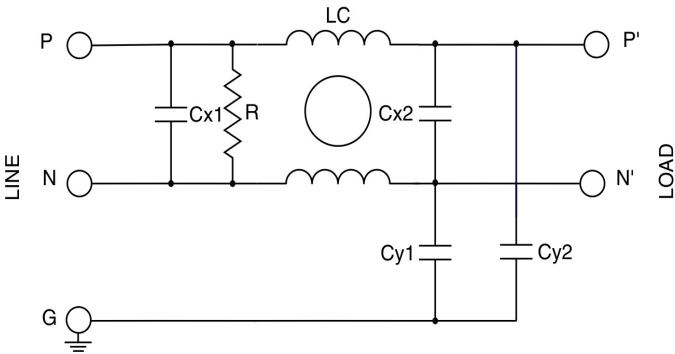



Approvals & Compliances





Technical Specifications

Maximum continuous operating voltage:	250 VAC, 50/60Hz, 250 VDC
Operating Frequency:	DC to 400Hz
Rated Currents:	1A to 30A @40°C
High Potential test voltage:	P to N 1075VDC for 2 Sec P to G 2250VDC for 2 Sec P to G 1500VAC 2 Sec (M Types)
Overload Capability:	4x rated current at switch on 1.5x rated current for 1 minute, once per hour
Design corresponding to:	UL 60939-3 and IEC 60939-1&2
Temperature range:	-25°C to +100°C
Climatic category:	25/100/21
Flammability corresponding to:	UL 94 V-0 or better
Protection category:	IP 20



Selection Table

STANDARD VERSION							
Available Part Numbers	Current Rating @ 40°C (A)	Leakage current @ 250 VAC/50 Hz (mA)	Power loss 50Hz (W)	Termination			Weight Approx. (g)
							
AMI-1030-1-1	1	0.173	1	-1	-	-	70
AMI-1030-1-3	1	0.173	1	-	-3	-	70
AMI-1030-3-1	3	0.26	2.5	-1	-	-	110
AMI-1030-3-3	3	0.26	2.5	-	-3	-	110
AMI-1030-4-1	4	0.26	3	-1	-	-	120
AMI-1030-4-3	4	0.26	3	-	-3	-	120
AMI-1030-6-1	6	0.37	3.5	-1	-	-	120
AMI-1030-6-3	6	0.37	3.5	-	-3	-	120
AMI-1030-8-1	8	0.37	4	-1	-	-	200
AMI-1030-8-3	8	0.37	4	-	-3	-	200
AMI-1030-10-1	10	0.37	5.5	-1	-	-	200
AMI-1030-10-3	10	0.37	5.5	-	-3	-	200
AMI-1030-12-1	12	0.8	8	-1	-	-	270
AMI-1030-12-3	12	0.8	8	-	-3	-	270
AMI-1030-16-1	16	0.8	6.5	-1	-	-	270
AMI-1030-16-3	16	0.8	6.5	-	-3	-	270
AMI-1030-16-M4	16	0.8	6.5	-	-	M4	270
AMI-1030-20-1	20	0.8	5	-1	-	-	330
AMI-1030-20-M4	20	0.8	5	-	-	M4	330
AMI-1030-30-M4	30	0.8	6	-	-	M4	350



Selection Table

SAFETY VERSION							
Available Part Numbers	Current Rating @ 40°C (A)	Leakage current @ 250 VAC/50 Hz (mA)	Power loss 50Hz (W)	Termination			Weight Approx. (g)
							
AMI-1030A-1-1	1	0.05	1	-1	-	-	70
AMI-1030A-1-3	1	0.05	1	-	-3	-	70
AMI-1030A-3-1	3	0.05	2.5	-1	-	-	110
AMI-1030A-3-3	3	0.05	2.5	-	-3	-	110
AMI-1030A-4-1	4	0.05	3	-1	-	-	120
AMI-1030A-4-3	4	0.05	3	-	-3	-	120
AMI-1030A-6-1	6	0.05	3.5	-1	-	-	120
AMI-1030A-6-3	6	0.05	3.5	-	-3	-	120
AMI-1030A-8-1	8	0.05	4	-1	-	-	200
AMI-1030A-8-3	8	0.05	4	-	-3	-	200
AMI-1030A-10-1	10	0.05	5.5	-1	-	-	200
AMI-1030A-10-3	10	0.05	5.5	-	-3	-	200
AMI-1030A-12-1	12	0.05	8	-1	-	-	270
AMI-1030A-12-3	12	0.05	8	-	-3	-	270
AMI-1030A-16-1	16	0.05	6.5	-1	-	-	270
AMI-1030A-16-3	16	0.05	6.5	-	-3	-	270
AMI-1030A-16-M4	16	0.05	6.5	-	-	M4	270
AMI-1030A-20-1	20	0.05	5	-1	-	-	330
AMI-1030A-20-M4	20	0.05	5	-	-	M4	330
AMI-1030A-30-M4	30	0.05	6	-	-	M4	350

Selection Table

MEDICAL VERSION							
Available Part Numbers	Current Rating @ 40°C (A)	Leakage current @ 250 VAC/50 Hz (mA)	Power loss 50Hz (W)	Termination			Weight Approx. (g)
							
AMI-1030B-1-1	1	0	1	-1	-	-	70
AMI-1030B-1-3	1	0	1	-	-3	-	70
AMI-1030B-3-1	3	0	2.5	-1	-	-	110
AMI-1030B-3-3	3	0	2.5	-	-3	-	110
AMI-1030B-4-1	4	0	3	-1	-	-	120
AMI-1030B-4-3	4	0	3	-	-3	-	120
AMI-1030B-6-1	6	0	3.5	-1	-	-	120
AMI-1030B-6-3	6	0	3.5	-	-3	-	120
AMI-1030B-8-1	8	0	4	-1	-	-	200
AMI-1030B-8-3	8	0	4	-	-3	-	200
AMI-1030B-10-1	10	0	5.5	-1	-	-	200
AMI-1030B-10-3	10	0	5.5	-	-3	-	200
AMI-1030B-12-1	12	0	8	-1	-	-	270
AMI-1030B-12-3	12	0	8	-	-3	-	270
AMI-1030B-16-1	16	0	6.5	-1	-	-	270
AMI-1030B-16-3	16	0	6.5	-	-3	-	270
AMI-1030B-16-M4	16	0	6.5	-	-	M4	270
AMI-1030B-20-1	20	0	5	-1	-		330
AMI-1030B-20-M4	20	0	5	-	-	M4	330
AMI-1030B-30-M4	30	0	6	-	-	M4	350

Selection Table

ENHANCED VERSION							
Available Part Numbers	Current Rating @ 40°C (A)	Leakage current @ 250 VAC/50 Hz (mA)	Power loss 50Hz (W)	Termination			Weight Approx. (g)
							
AMI-1030N-1-1	1	5.35	1	-1	-	-	70
AMI-1030N-3-1	3	3.69	2.5	-1	-	-	110
AMI-1030N-4-1	4	3.69	3	-1	-	-	120
AMI-1030N-6-1	6	3.69	3.5	-1	-	-	120
AMI-1030N-8-1	8	5.35	4	-1	-	-	200
AMI-1030N-10-1	10	5.35	5.5	-1	-	-	200
AMI-1030N-12-1	12	5.35	8	-1	-	-	270
AMI-1030N-16-1	16	3.69	6.5	-1	-	-	270
AMI-1030N-16-M4	16	3.69	6.5	-	-	M4	270
AMI-1030N-20-1	20	3.69	5	-1	-	-	330
AMI-1030N-20-M4	20	3.69	5	-	-	M4	330
AMI-1030N-30-M4	30	3.69	6	-	-	M4	350

Mechanical Drawing

Connection style -1, 1A types

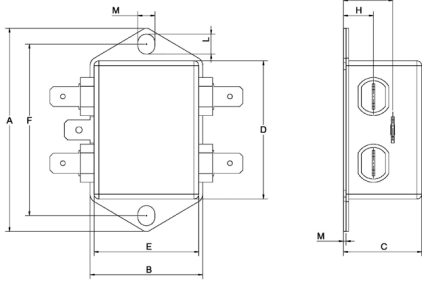

Connection style -1, 3A to 6A types

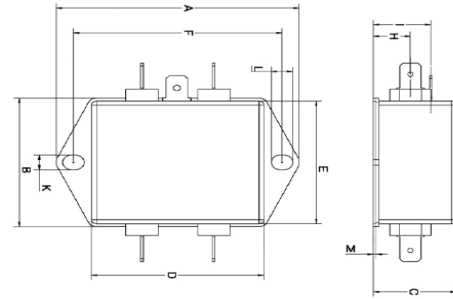

Connection style -1, 8A to 12A types

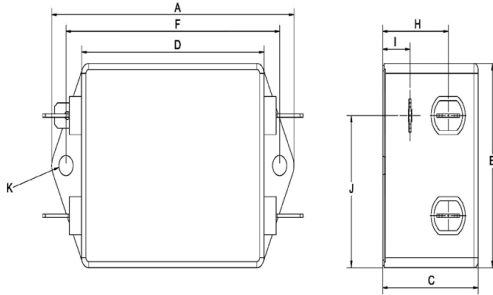

Connection style -1, 16A to 30A type

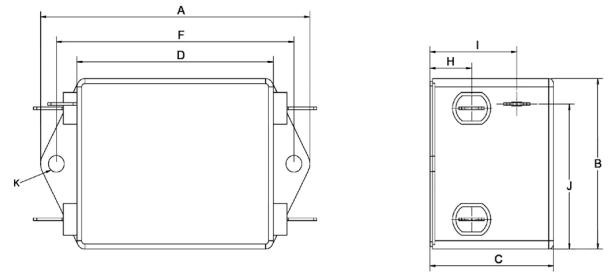

Connection style -3, 1A to 6A types (same dimensions as style -1)

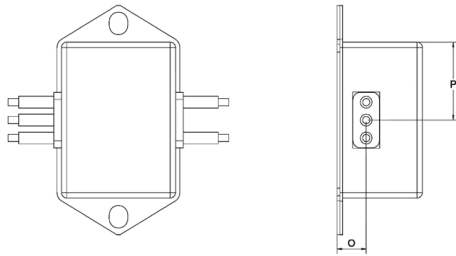

Connection style -3, 8A to 16A types (same dimensions as style-1)

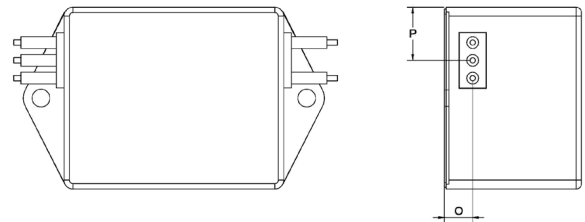

Connection style -6, 16A to 30A types

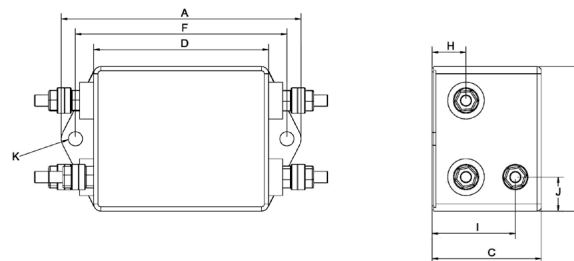

Mechanical Dimensions:

	1A	3A	4A	6A	8A	10A	12A	16A	20A	30A
A	64±1	71±1	71±1	71±1	85±1	85±1	85±1	85±1	85±1	85±1
B	35±1	46.6±1	46.6±1	46.6±1	51±1	51±1	51±1	51±1	51±1	51±1
C	24.3±1	22.3±1	22.3±1	22.3±1	32.5±1	32.5±1	32.5±1	39±1	39±1	39±1
D	43.5±1	50.5±1	50.5±1	50.5±1	64±1	64±1	64±1	62±1	62±1	62±1
E	32.5	44.5	44.5	44.5	-	-	-	-	-	-
F	54	61	61	61	75	75	75	75	75	75
H	9.3	10.8	10.8	10.8	21.5	21.5	21.5	13	13	13
I	15.3	16.8	16.8	16.8	9	9	9	27.5	27.5	27.5
K	5.3	5.3	5.3	5.3	5	5	5	5	5	5
L	6.3	6.3	6.3	6.3	-	-	-	-	-	-
M	0.8	0.8	0.8	0.8	0.8	0.8	0.8	0.8	0.8	0.8
Connection Style-1	-	-	-	-	-	-	-	-	-	-
N	6.3x0.8	6.3X0.8	6.3X0.8	6.3X0.8	6.3X0.8	6.3X0.8	6.3X0.8	6.3X0.8	6.3X0.8	
Connection Style-3	-	-	-	-	-	-	-	-	-	-
O	8.3	8.3	8.3	8.3	8.3	8.3	8.3	8.3	-	-
P	21.8	14	14	14	14.9	14.9	14.9	14.9	-	-
AWG Type Wire	AWG 20	AWG 20	AWG 20	AWG 18	AWG 18	AWG 18	AWG 16	AWG 16	-	-
Wire Length	140	140	140	140	140	140	140	140	-	-
Connection Style-6	-	-	-	-	-	-	-	-	-	-
N	-	-	-	-	-	-	-	M4	M4	M4
Recommended torque (Nm)	-	-	-	-	-	-	-	1.2-1.3	1.2-1.3	1.2-1.3
Earth terminal Recommended torque (Nm)	-	-	-	-	-	-	-	1.5-1.7	1.5-1.7	1.5-1.7

Typical Insertion Loss

According to CISPR17 in 50 Ω system

— Common Mode / Asymmetrical (L-G)
 — Differential Mode / Symmetrical (L-L)

1A Standard Version

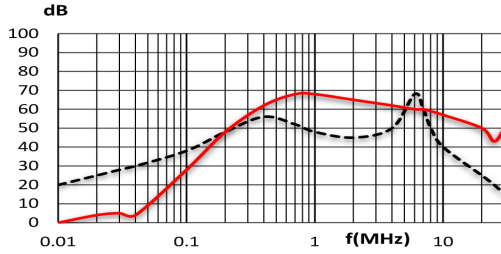

Safety Version

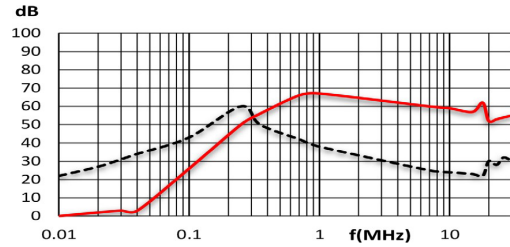

Medical Version

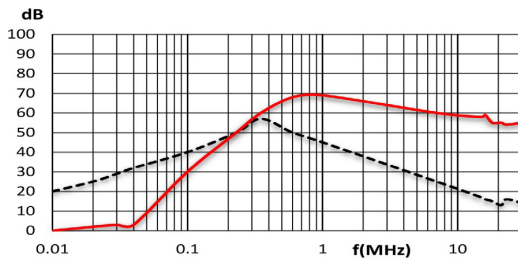

Enhanced Performance

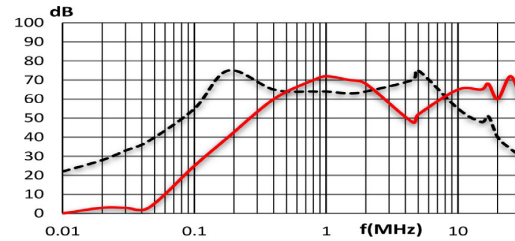

3A Standard Version

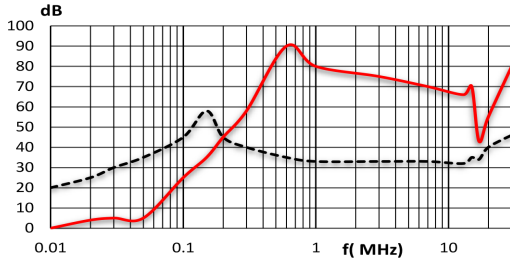

Safety Version

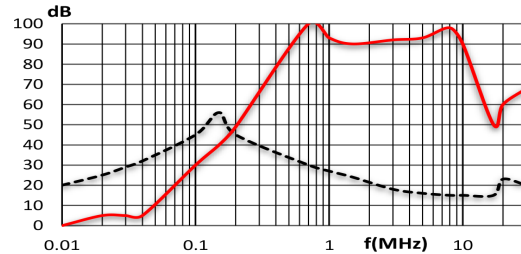

Medical Version

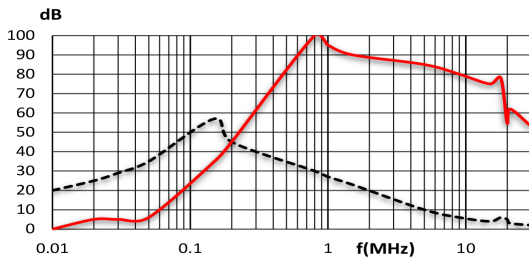

Enhanced Performance

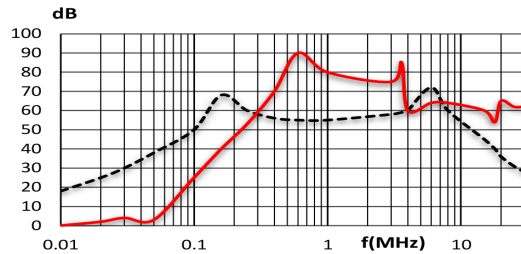

4A Standard Version

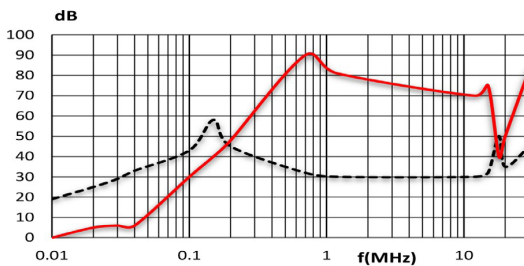

Safety Version

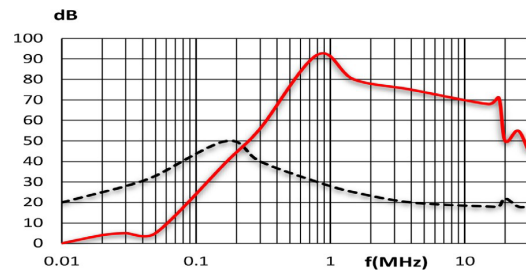

Typical Insertion Loss

According to CISPR17 in 50 Ω system

— Common Mode / Asymmetrical (L-G)
 — Differential Mode / Symmetrical (L-L)

Medical Version

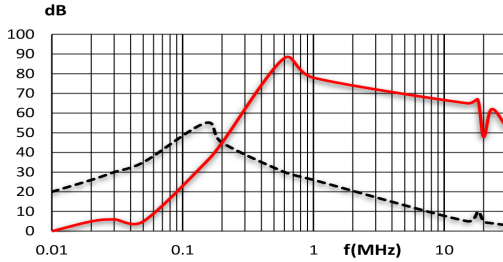

Enhanced Performance

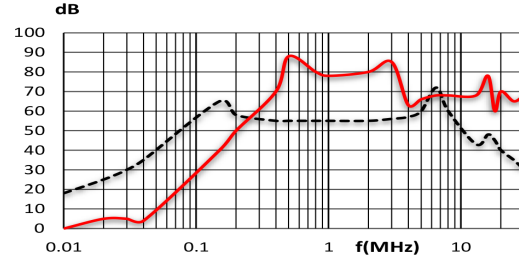

6A Standard Version

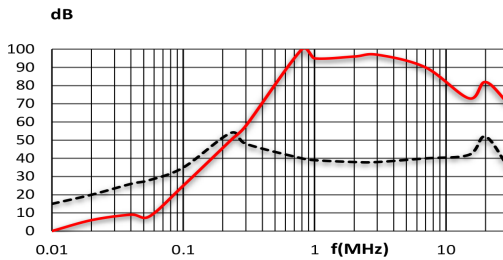

Safety Version

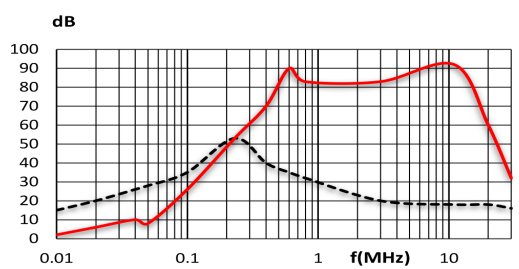

Medical Version

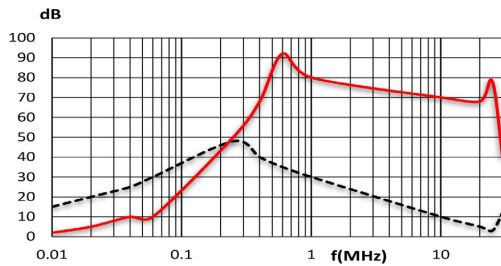

Enhanced Performance

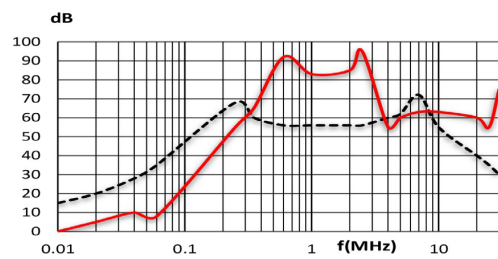

8A Standard Version

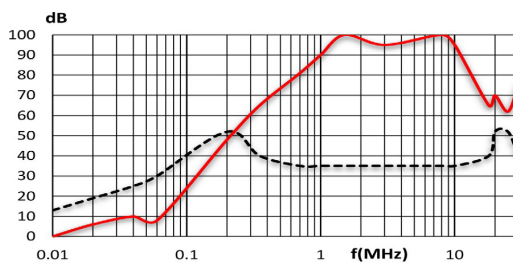

Safety Version

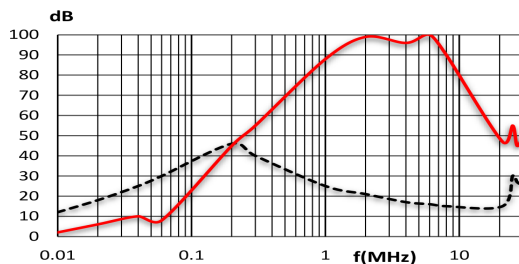

Medical Version

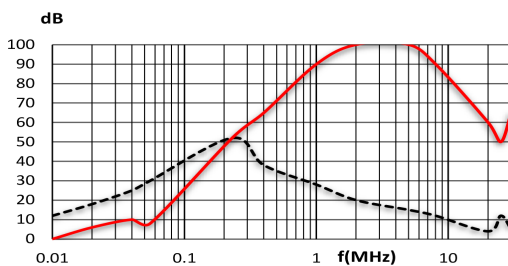

Enhanced Performance

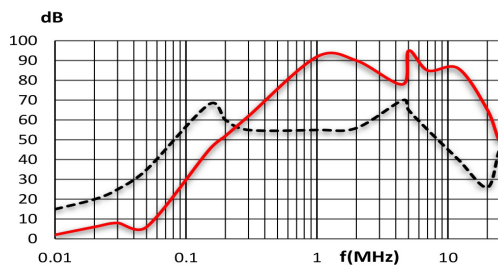

Typical Insertion Loss

According to CISPR17 in 50 Ω system

— Common Mode / Asymmetrical (L-G)
 — Differential Mode / Symmetrical (L-L)

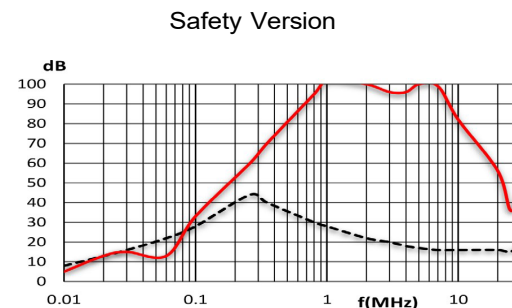
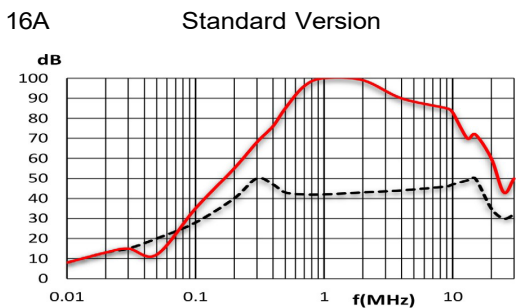
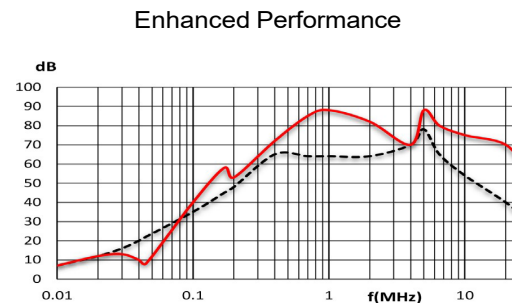
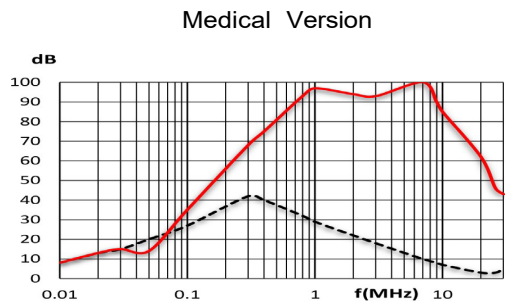
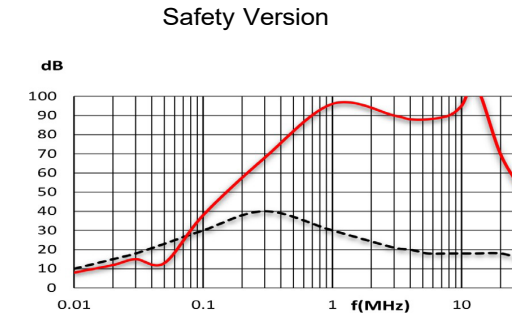
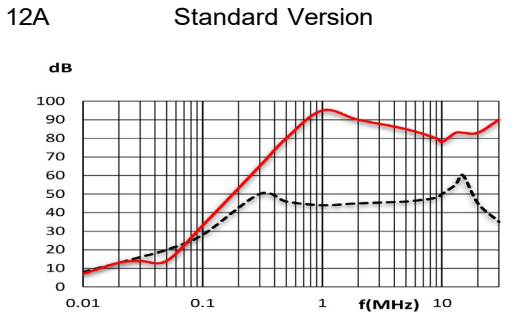
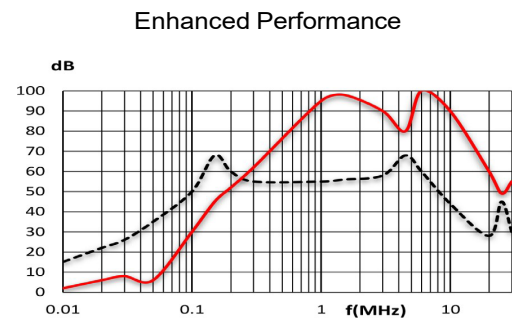
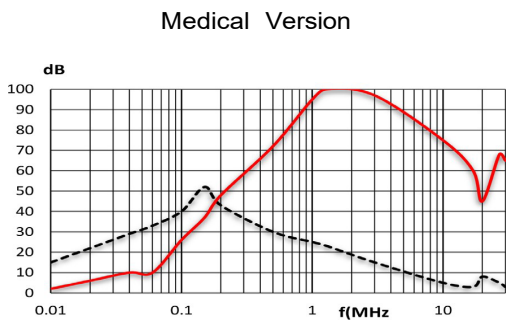
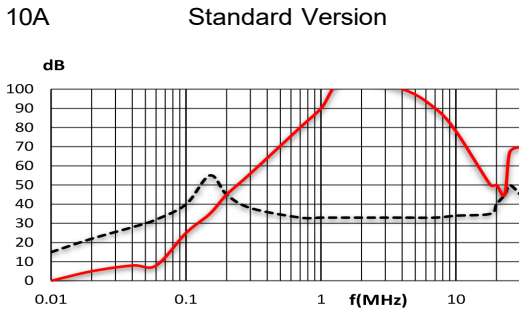

Typical Insertion Loss

According to CISPR17 in 50 Ω system

— Common Mode / Asymmetrical (L-G)
 — Differential Mode / Symmetrical (L-L)

Medical Version

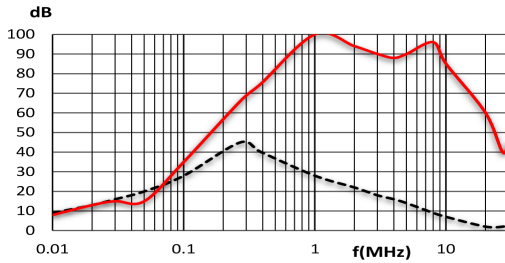

Enhanced Performance

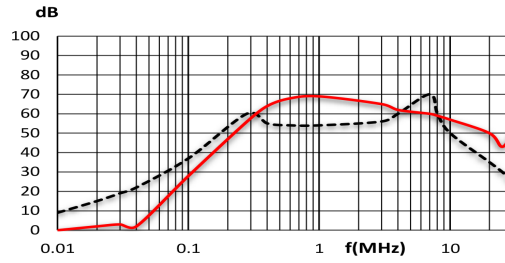

20A Standard Version

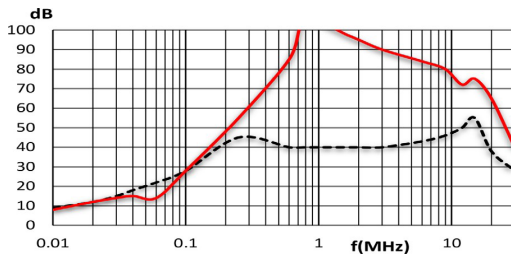

Safety Version

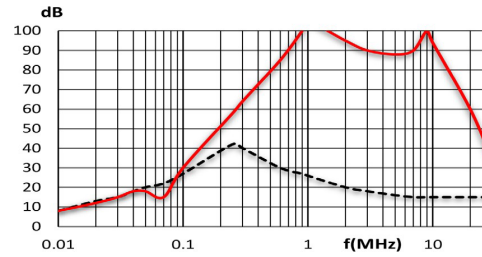

Medical Version

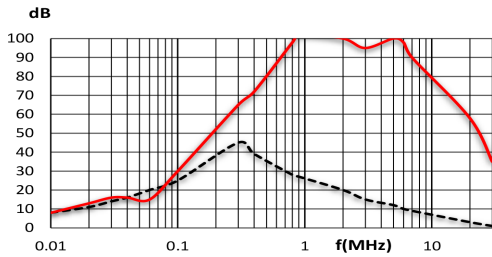

Enhanced Performance

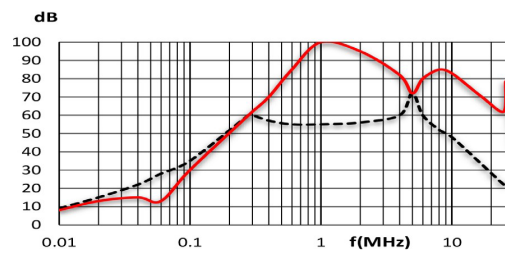

30A Standard Version

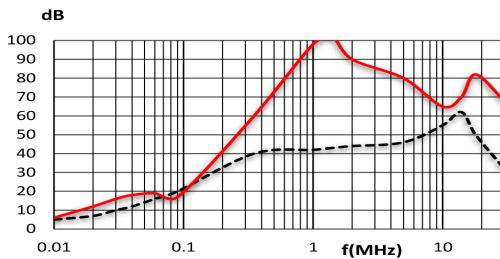

Safety Version

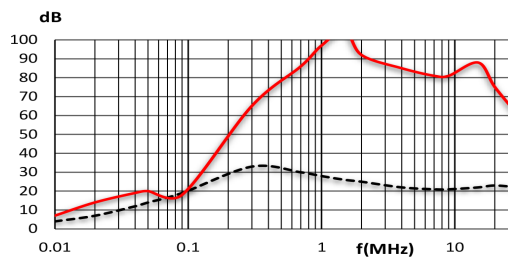

Medical Version

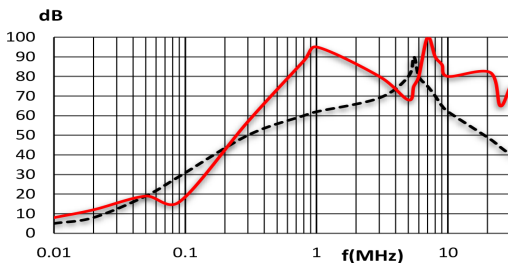

Enhanced Performance

