

## Features

- Standard Attenuation Performance
- Rated up to 150A
- Chassis mounting 3 Phase Filter 4 Wire
- Low Cost

## Applications

- CNC Machines
- Electronic Equipment
- Rectifier
- UPS/Inverters

## Typical Circuit Diagram

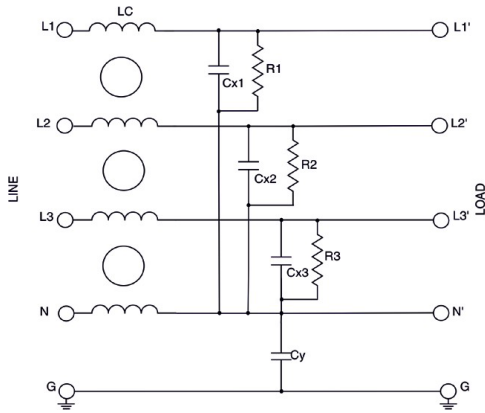

## Performance Indicator

Standard	High	Very High
■		

Rated current [A]

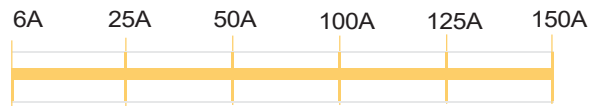



## Approvals & Compliances



## Technical Specifications

Maximum Continuous Operating Voltage	440/520VAC
Operating Frequency	50/60 Hz
Current ratings	1A to 150A @ 40°C
High Potential test voltage	L to G 2660Vdc for 1 Minute L to L 1950Vdc for 1 Minute
Overload Capability	135% of Rated current for 15 minutes
Design Corresponding to	UL 60939-3, CSA 22.2 No.8-13 and IEC60939-1&2
Flammability corresponding to	UL 94 V-0
Temperature range	-25°C to +85°C

## Selection Table

Available Part Numbers (for 440VAC)	Available Part Numbers (for 520VAC)	Leakage Current (mA)	Rated Current @40°C	Termination			Weight (Kg)
							
AMI-4355-1-1	AMI-4355H-1-1	3	1A	6.3 X 0.8			0.26
AMI-4355-3-1	AMI-4355H-3-1	3	3A	6.3 X 0.8			0.26
AMI-4355-6-1	AMI-4355H-6-1	3	6A	6.3 X 0.8			0.26
AMI-4355-10-1	AMI-4355H-10-1	3	10A	6.3 X 0.8			0.26
AMI-4355-15-M5	AMI-4355H-15-M5	3	15A		M5		0.7
AMI-4355-16-M5	AMI-4355H-16-M5	3	16A		M5		0.7
AMI-4355-20-M5	AMI-4355H-20-M5	3	20A		M5		0.7
AMI-4355-25-M5	AMI-4355H-25-M5	5	25A		M5		0.7
AMI-4355-26-M5	AMI-4355H-26-M5	5	26A		M5		0.7
AMI-4355-30-M5	AMI-4355H-30-M5	5	30A		M5		0.7
AMI-4355-32-M5	AMI-4355H-32-M5	5	32A		M5		0.7
AMI-4355-40-M5	AMI-4355H-40-M5	5	40A		M5		0.7
AMI-4355-50-M6	AMI-4355H-50-M6	5	50A		M6		1.2
AMI-4355-60-M6	AMI-4355H-60-M6	5	60A		M6		1.2
AMI-4355-75-M8	AMI-4355H-75-M8	6	75A		M8		9
AMI-4355-75-16	AMI-4355H-75-16	6	75A			16	9
AMI-4355-80-M8	AMI-4355H-80-M8	6	80A		M8		9
AMI-4355-80-25	AMI-4355H-80-25	6	80A			25	9
AMI-4355-100-M10	AMI-4355H-100-M10	6	100A		M10		9
AMI-4355-100-25	AMI-4355H-100-25	8	100A			25	9
AMI-4355-125-M10	AMI-4355H-125-M10	8	125A		M10	25	9
AMI-4355-150-M10	AMI-4355H-150-M10	8	150A		M10	25	9

## Mechanical Drawing

### 1A to 10A

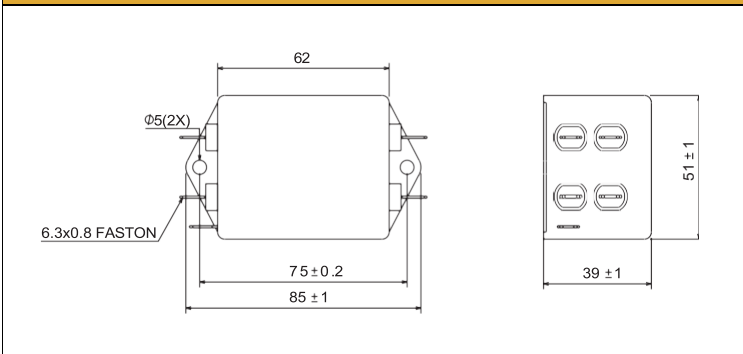

### 15A to 40A

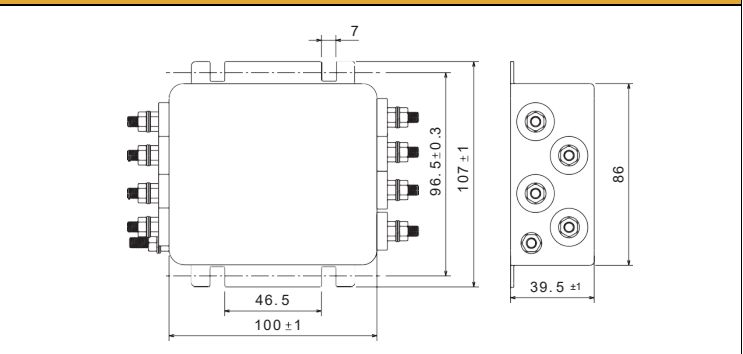

### 50A to 60A

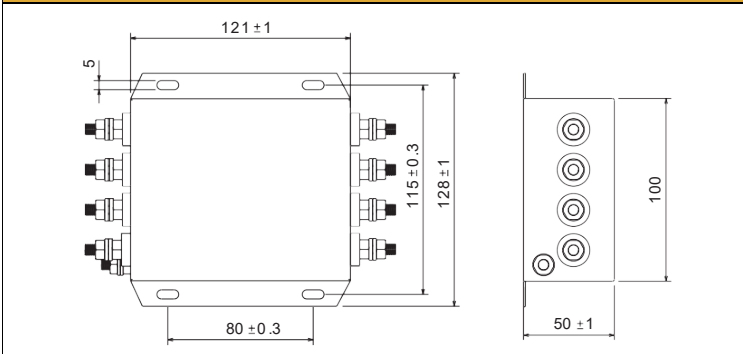

### 75A to 150A

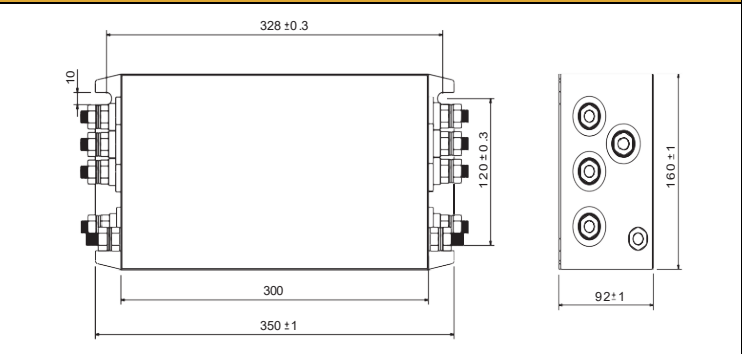

### 75A to 100A (Connector Type)

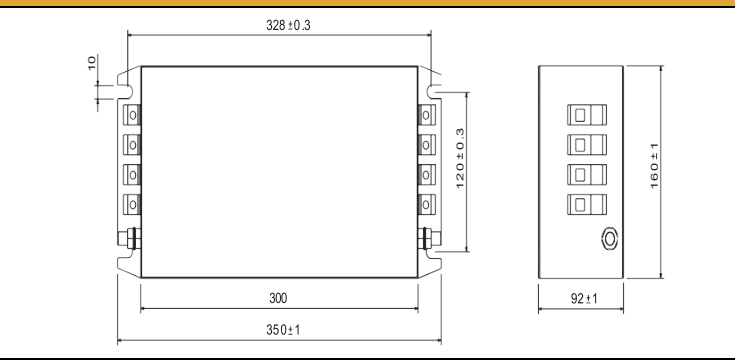

## Connectors Cross Sections

	16	25
Wire Section (mm <sup>2</sup> )	16mm <sup>2</sup>	25mm <sup>2</sup>
Wire Section (AWG)	6 AWG	4 AWG
Wire Stripping	Max 17mm	Max 17mm
Max Recommended Torque	2-2.2 Nm / 18-19.8 in.lbs	2 Nm / 18 in.lbs

## For Screw Type

Thread Size	M5	M6	M8	M10
Recommended Torque (Nm)	2	3.5-4	8-9	15-17
Earth Terminal (Nm)	2	3.5-4	8-9	15-17

## Typical Insertion Loss

According to CISPR17 in 50 Ω system

— Common Mode / Asymmetrical (L-G)  
— Differential Mode / Symmetrical (L-L)

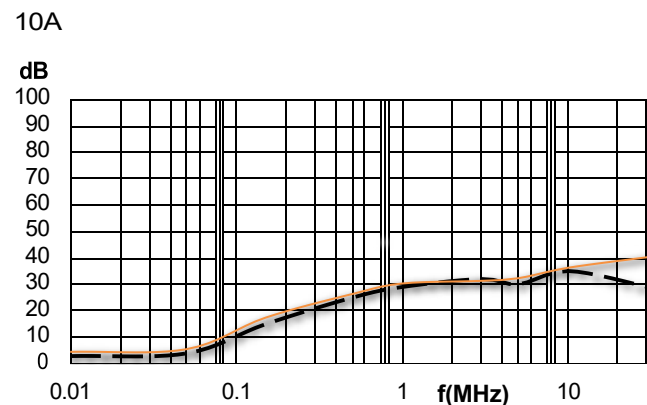
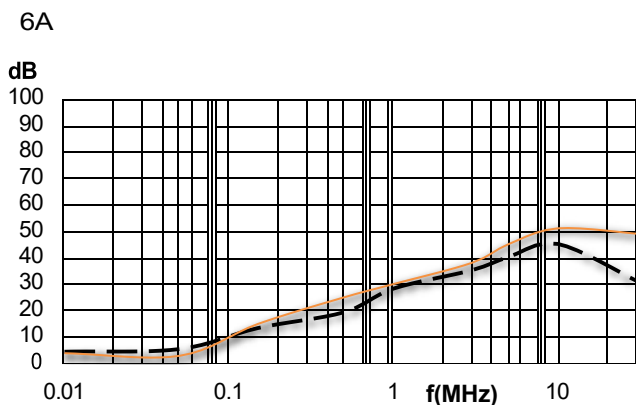
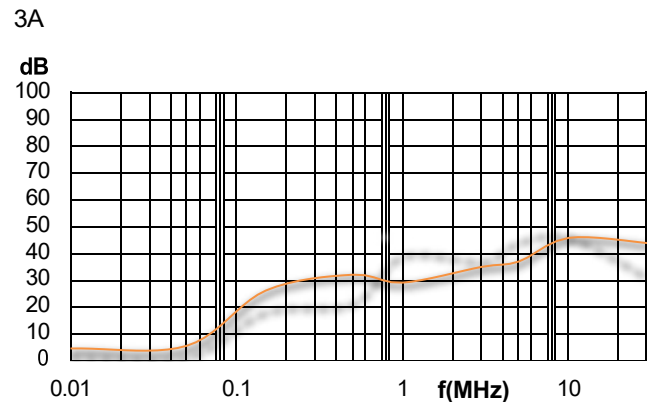
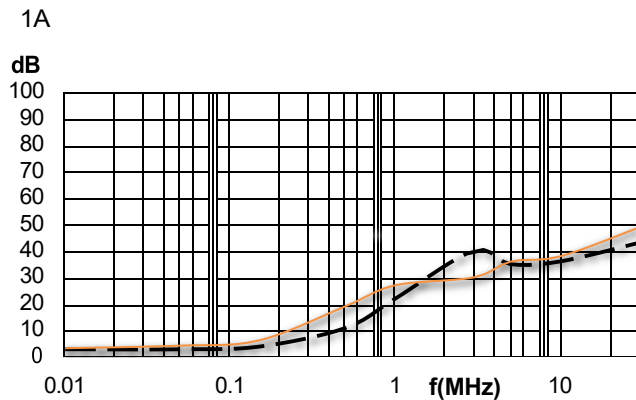

## Typical Insertion Loss

According to CISPR17 in 50  $\Omega$  system

— Common Mode / Asymmetrical (L-G)  
— Differential Mode / Symmetrical (L-L)

15A

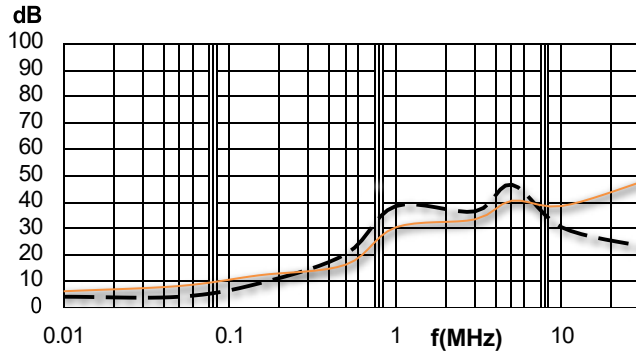

20A

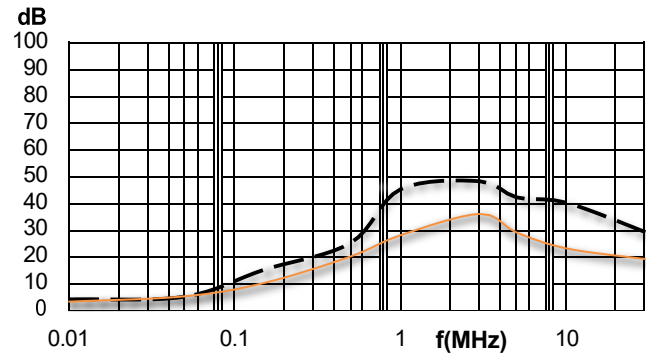

25A

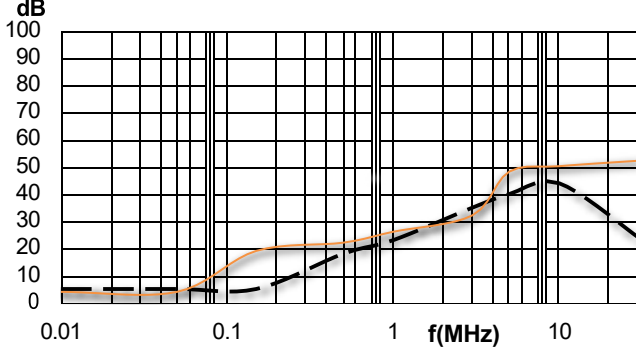

30A

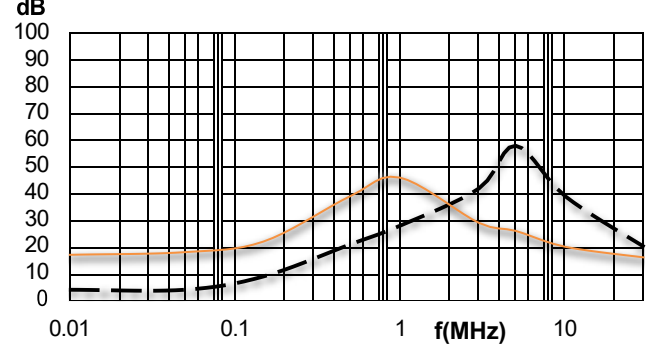

40A

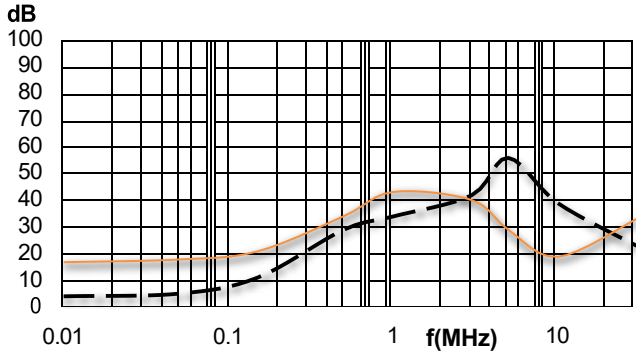

50A

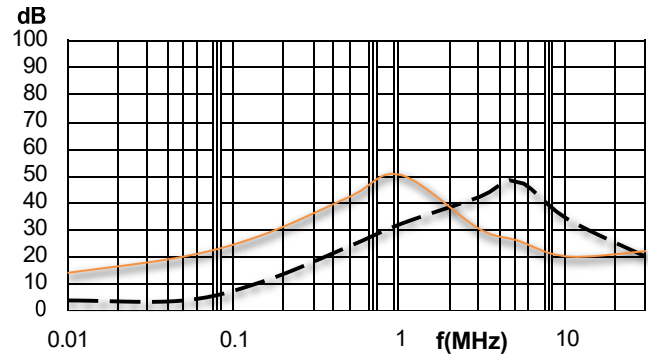

60A

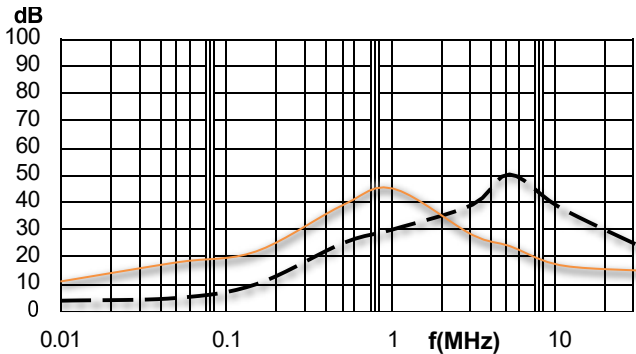

75A

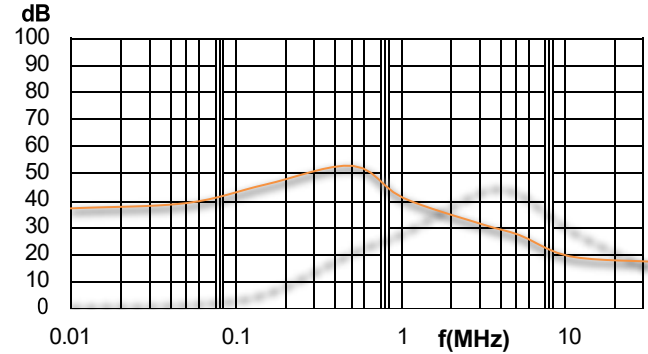

## Typical Insertion Loss

According to CISPR17 in 50 Ω system

— Common Mode / Asymmetrical (L-G)  
— Differential Mode / Symmetrical (L-L)

