

## Features

- Compact
- Rated up to 250A
- Superior Performance
- Chassis mounting Three Phase Filter

## Applications

- CNC Machines
- Drives
- Convertors
- HVAC

## Typical Circuit Diagram

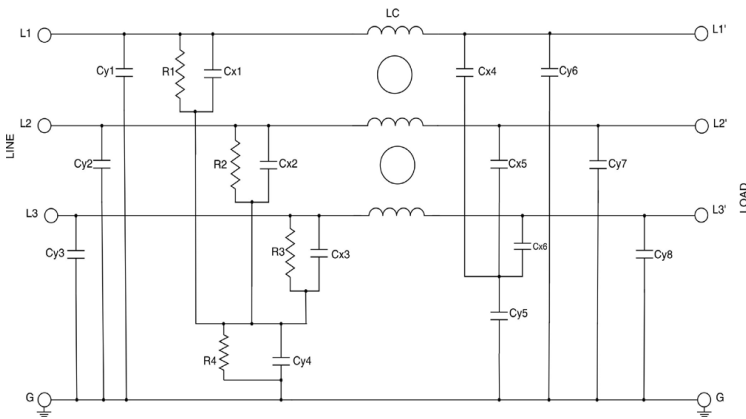

## Performance Indicator

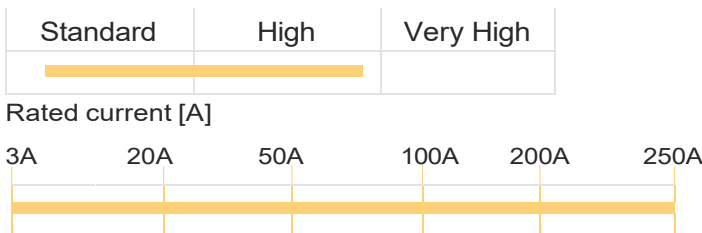



## Approvals & Compliances



## Technical Specifications

Maximum Continuous Operating Voltage	440/520VAC
Operating Frequency	50/60Hz
Current ratings	3A to 250A @40°C
High Potential test voltage	L to G 2660VDC for 1 Minute L to L 1950VDC for 1 Minute
Overload Capability	135% of Rated current for 15 minutes
Design Corresponding to	UL 60939-3, CSA 22.2 No.8-13 and IEC60939-1&2
Flammability corresponding to	UL 94 V-0
Temperature range	-25°C to +85°C
Climatic Category	25/85/21

## Selection Table

Available Part Number (440VAC)	Available Part Number (520VAC)	Rated Current @40C	Leakage current (mA)	Termination		Weight (Grams)
						
AMI-3361-3-04	AMI-3361H-3-04	3A	8.5	41		0.6
AMI-3361-6-04	AMI-3361H-6-04	6A	8.5	41		0.7
AMI-3361-8-04	AMI-3361H-8-04	8A	8.5	41		2
AMI-3361-10-04	AMI-3361H-10-04	10A	8.5	41		2
AMI-3361-15-04	AMI-3361H-15-04	15A	8.5	41		3
AMI-3361-16-04	AMI-3361H-16-04	16A	8.5	41		3
AMI-3361-20-04	AMI-3361H-20-04	20A	8.5	41		3
AMI-3361-25-04	AMI-3361H-25-04	25A	8.5	41		3
AMI-3361-36-10	AMI-3361H-36-10	36A	8.5	10		3
AMI-3361-50-10	AMI-3361H-50-10	50A	8.5	10		3
AMI-3361-60-16	AMI-3361H-60-16	60A	12	16		8
AMI-3361-75-16	AMI-3361H-75-16	75A	12	16		8
AMI-3361-80-25	AMI-3361H-80-25	80A	12	25		8
AMI-3361-100-25	AMI-3361H-100-25	100A	12	25		8
AMI-3361-125-M10	AMI-3361H-125-M10	125A	12		M10	9
AMI-3361-150-M10	AMI-3361H-150-M10	150A	12		M10	9
AMI-3361-160-M10	AMI-3361H-160-M10	160A	12		M10	9
AMI-3361-200-M10	AMI-3361H-200-M10	200A	12		M10	9
AMI-3361-250-M10	AMI-3361H-250-M10	250A	12		M10	9

## Mechanical Drawing

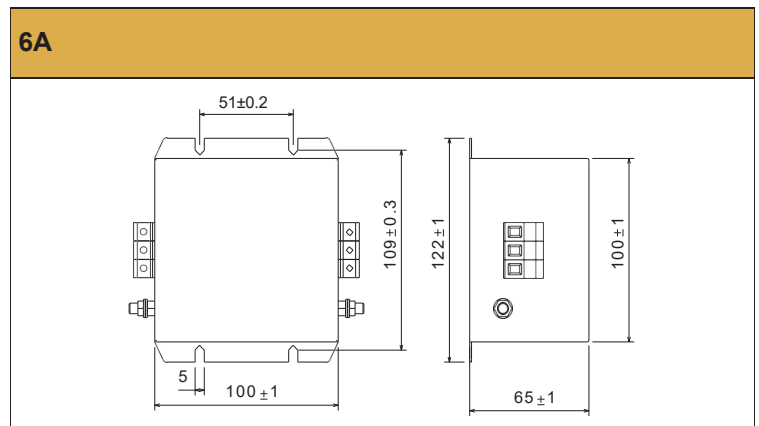
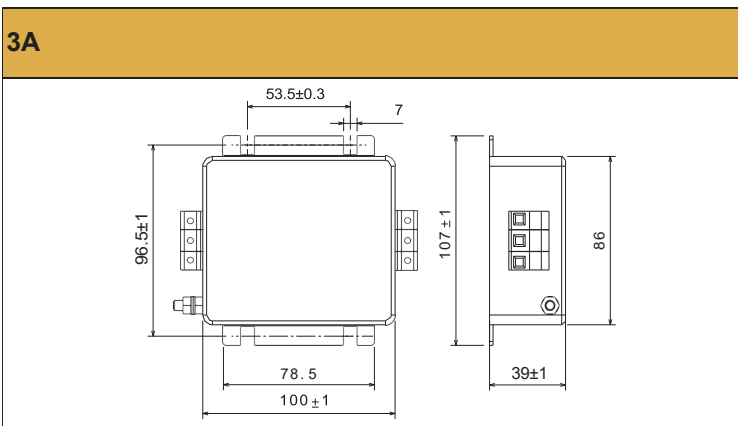

## Mechanical Drawing

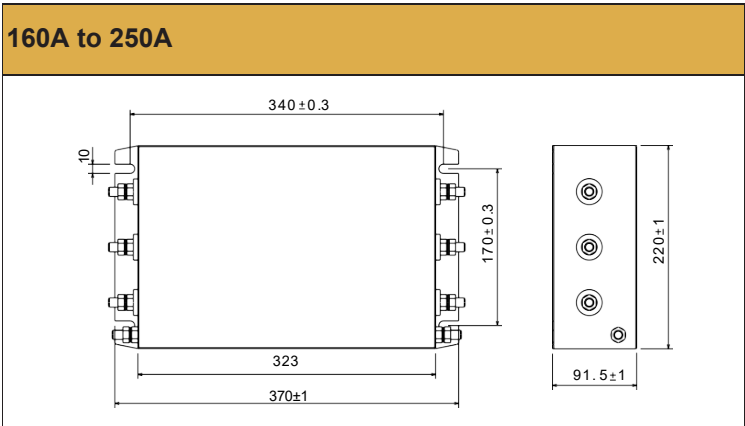
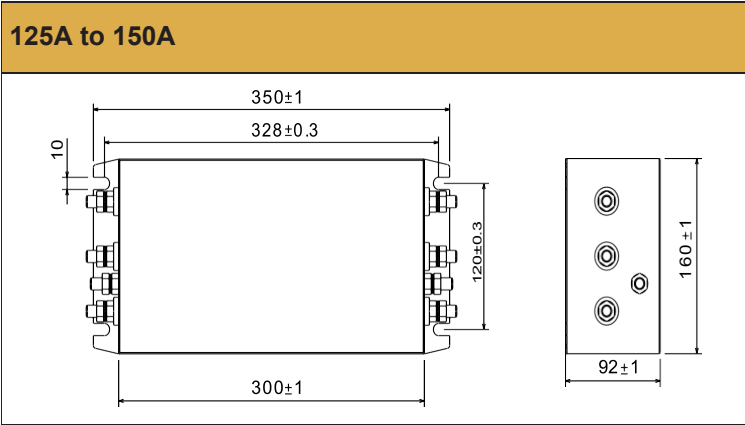
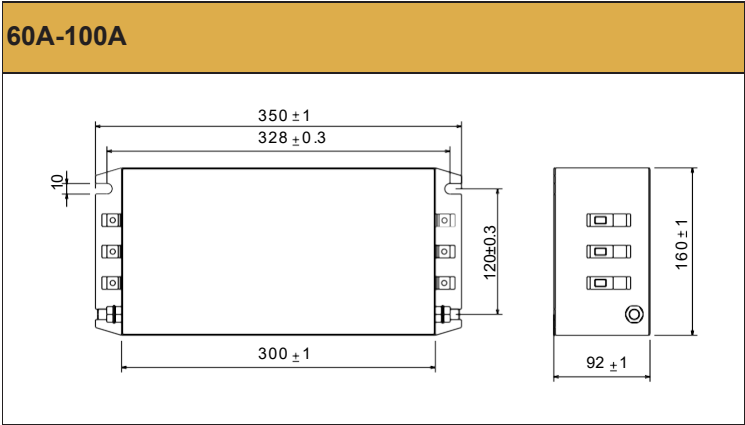
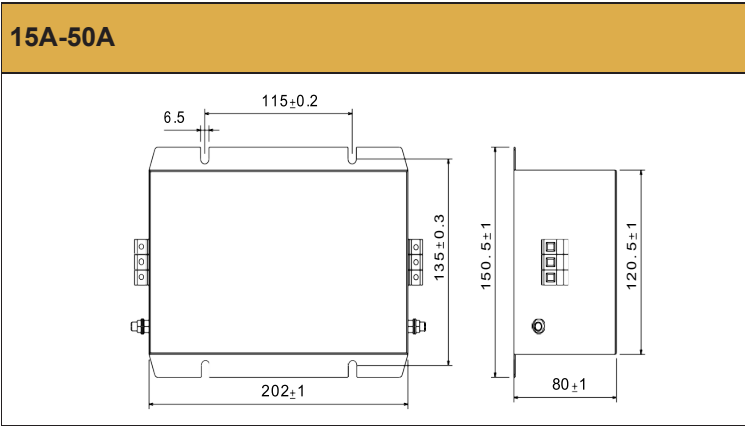
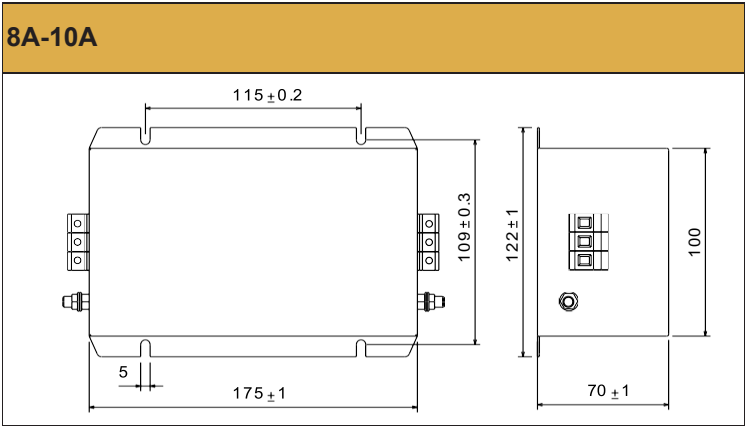

Thread Size	M10
Recommended Torque (Nm)	15-17
Earth Terminal (Nm)	15-17

	04	10	16	25
Wire Section (mm <sup>2</sup> )	4mm <sup>2</sup>	10mm <sup>2</sup>	16mm <sup>2</sup>	25mm <sup>2</sup>
Wire Section (AWG)	12AWG	8 AWG	6 AWG	4 AWG
Wire Stripping	Max 10mm	Max 13.5mm	Max 17mm	Max 17mm
Max Recommended Torque	0.5 Nm / 4.5 in.lbs	2 Nm / 18 in.lbs	2-2.2 Nm / 18-19.8 in.lbs	2 Nm / 18 in.lbs

## Typical Insertion Loss

According to CISPR17 in 50 Ω system

— Common Mode / Asymmetrical (L-G)  
 — Differential Mode / Symmetrical (L-L)

**3A**

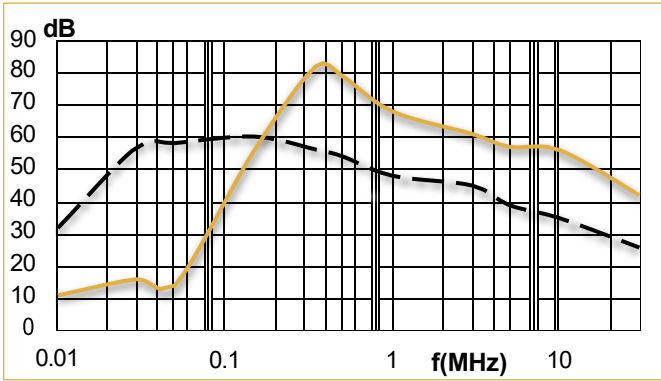

**6A**

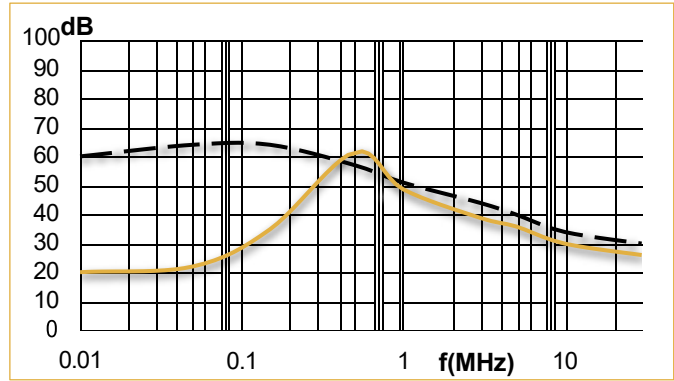

**8A**

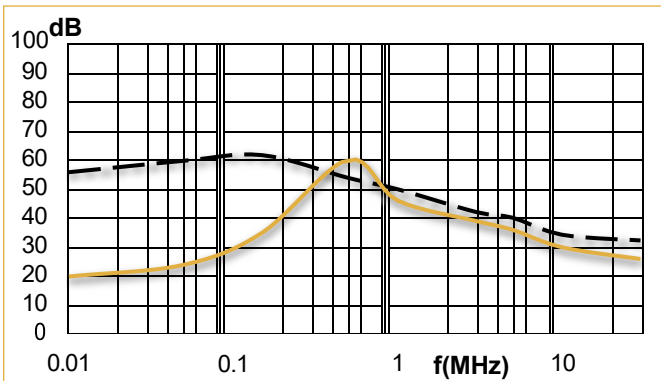

**10A**

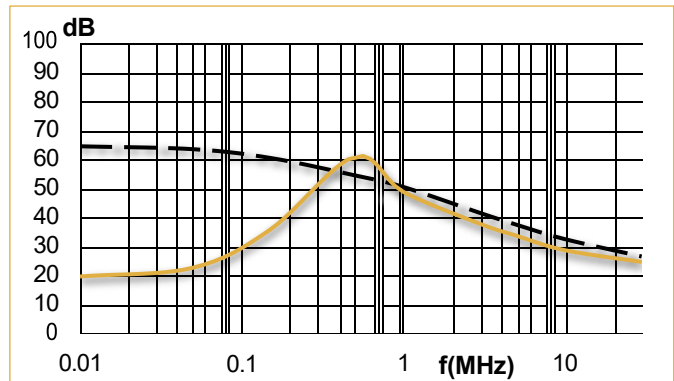

**16A**

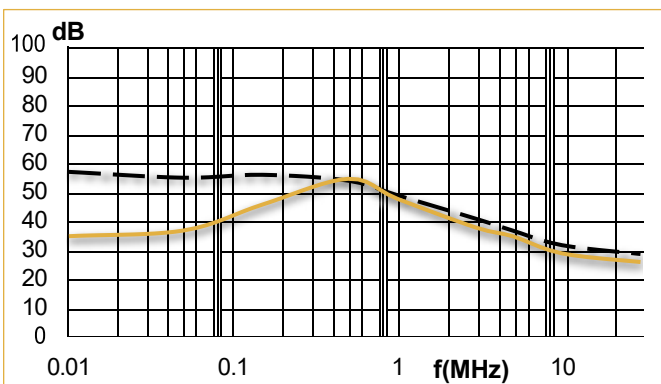

**20A**

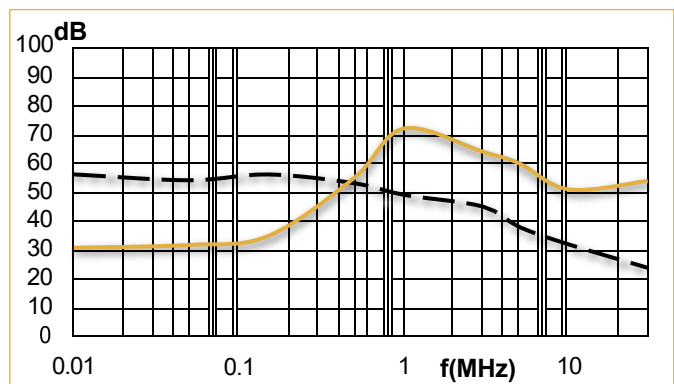

## Typical Insertion Loss

According to CISPR17 in 50 Ω system

— Common Mode / Asymmetrical (L-G)  
 — Differential Mode / Symmetrical (L-L)

**25A**

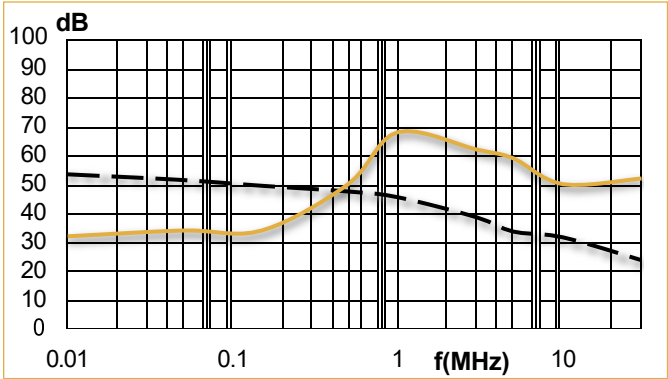

**36A**

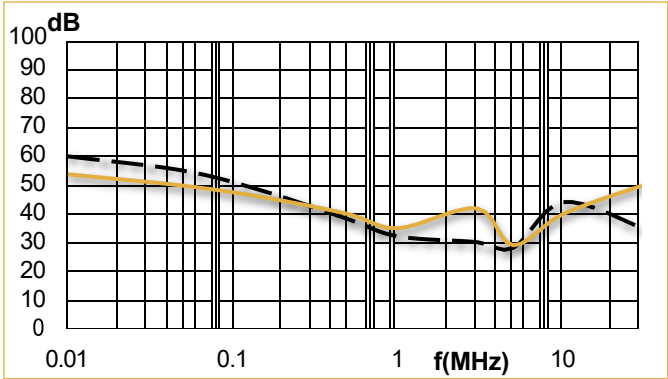

**50A**

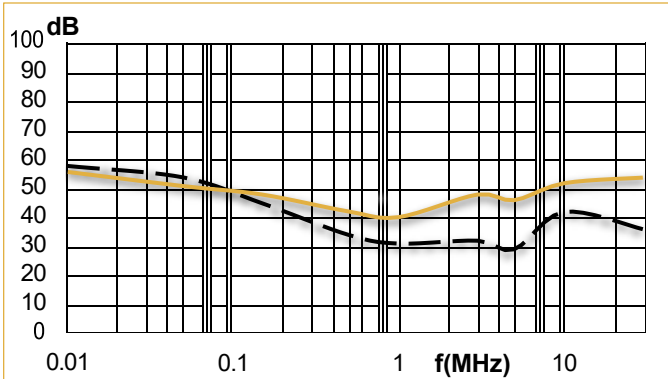

**60A**

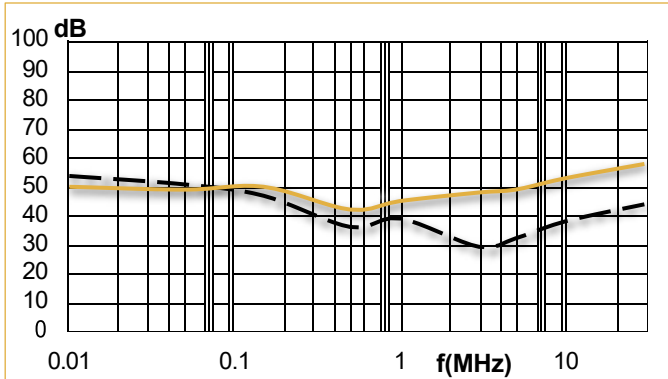

**75A**

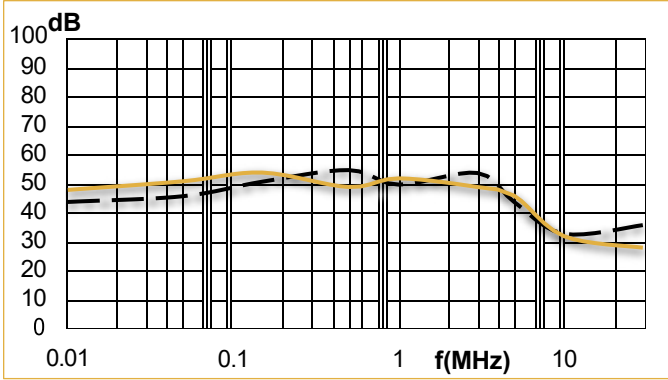

**80A**

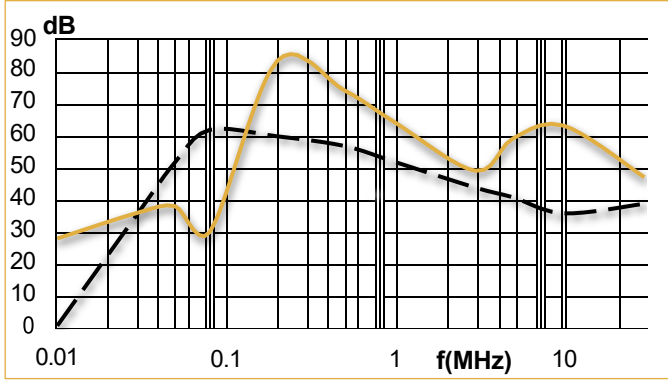

## Typical Insertion Loss

According to CISPR17 in 50 Ω system

— Common Mode / Asymmetrical (L-G)  
 — Differential Mode / Symmetrical (L-L)

**100A**

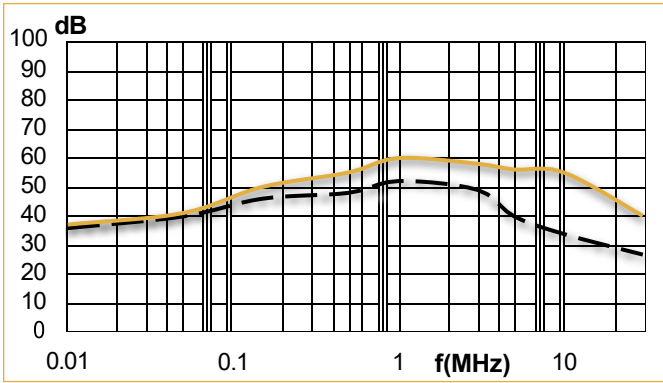

**125A**

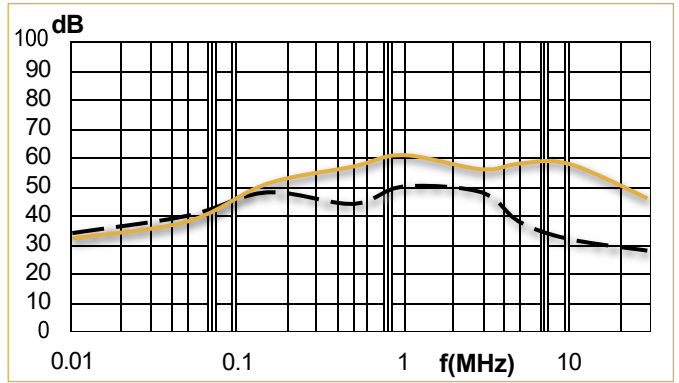

**150A**

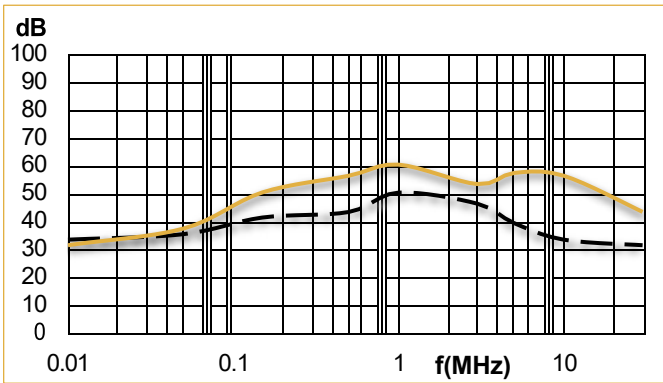

**160A**

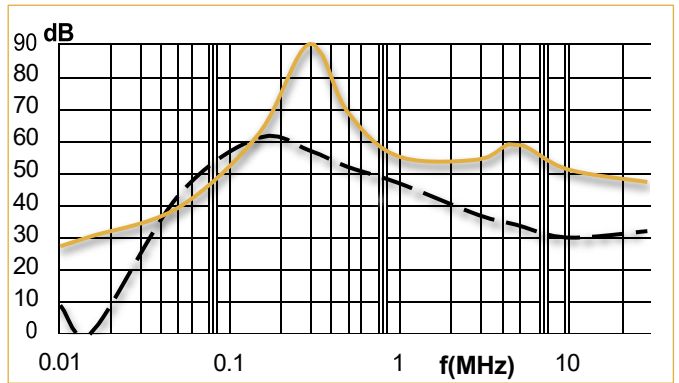

**200A**

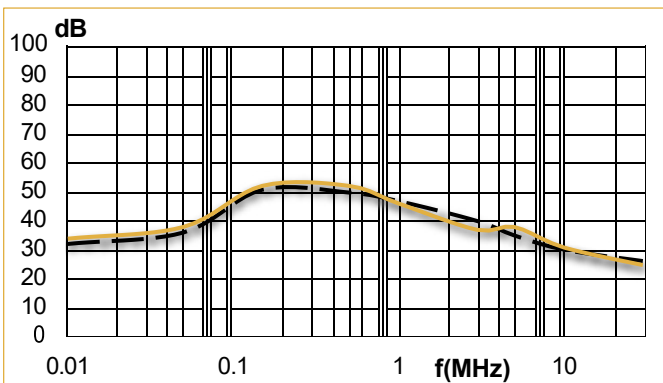

**250A**

