

Features

HIGH CURRENT CARRY AND HIGH VOLTAGE

Inert gas filled arc chamber suitable for high voltage switching

COMPACT STRUCTURE, LOW NOISE

Small, low-profile design with low noise while carrying or switching loads

SAFE FOR EXPLOSIVE ENVIRONMENTS

No arc leakage due to a hermetically sealed design

HIGH RELIABILITY DESIGN

Hermetic sealing creates a stable environment for high voltage switching

NO SPECIFIC MOUNTING ARRANGEMENT

Mountable in any orientation without reduction of performance

VARIOUS APPLICATIONS

Battery disconnect, EV charging, energy storage systems, photovoltaics, power control, circuit protection and much more

Sealing Type: Ceramic



Certification Information

1. Meet RoHS (2011/65/EU)
2. CE certified

Nomenclature

AEVT60

B

-

Series code:

“AEVT60” = AEVT60

Coil Voltage Code:

“B” = 12VDC

“C” = 24VDC

Options (applied in this order):

Blank = Std. Options (Bottom Mount, Without Aux)

Product Data Sheet

MAIN CONTACT

| | | |
|---|--------------------------|-------------------------------|
| Contact Arrangement | 1 Form X (SPST-NO) | |
| Rated Operating Voltage | 750 VDC | |
| Rated Current | 60A (@750VDC) | |
| Max Short Circuit Current | 3000A (1s) | |
| Dielectric Withstanding Voltage (initial) | Between Open Contacts | 4000VDC 1mA 1min |
| | Between Contacts to Coil | 3000VAC 1mA 1min |
| Insulation Resistance (initial) | Terminal to Terminal | Min. 1000 M Ω @1000VDC |
| | Terminals to Coil | |
| Contact Voltage Drop(initial) | Max. 150mV (60A) | |

OPERATE / RELEASE TIME

| | |
|--------------------------------|------------------|
| Operate Time (includes bounce) | 30ms, Max. @20°C |
| Release Time | 10ms, Max @20°C |

ENVIRONMENTAL DATA

| | | |
|-----------------------|-----------------|---|
| Shock | Functional | 196m/s ² Sine half-wave pulse |
| | Destructive | 490m/s ² Sine half-wave pulse |
| Operating Temperature | -40 to +85°C | |
| Humidity | 5% to 85%RH | |
| Weight | 0.55Lb (0.25kg) | |

EXPECTED LIFE

| | |
|---|----------------|
| Electrical Life (make/break) 60A@750VDC | 3,000 Cycles |
| Electrical Life (make/break) 10A@750VDC | 50,000 Cycles |
| Mechanical Life | 200,000 Cycles |

COIL DATA

| | | |
|--|-------------|-------------|
| Nominal Voltage | 12VDC | 24VDC |
| Max. Pick-up Voltage (20°C) | 9VDC | 18VDC |
| Min. Drop-out Voltage (20°C) | 1VDC | 2VDC |
| Coil Power 20°C at Nominal Voltage | 5.2W | 5.2W |
| Rated Coil Resistance \pm 10% (20°C) | 28 Ω | 96 Ω |
| Holding Current (Max) | 0.44A | 0.22A |

Current Carry Curve

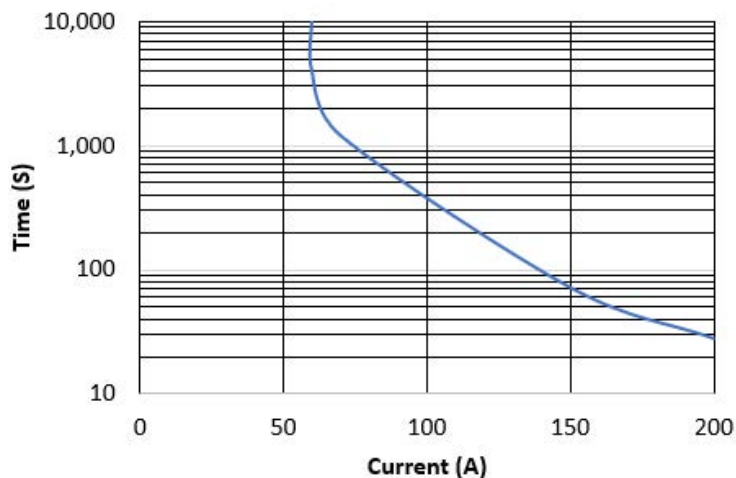

Note:

- Do not meet dielectric & IR after the test.
- ON:OFF= 0.6s:5.4s.
- The ambient environment of application should not cause any dewing or icing inside the relay. Otherwise, the relay may fail to work consequently.

Outline Dimensions : inches (mm)

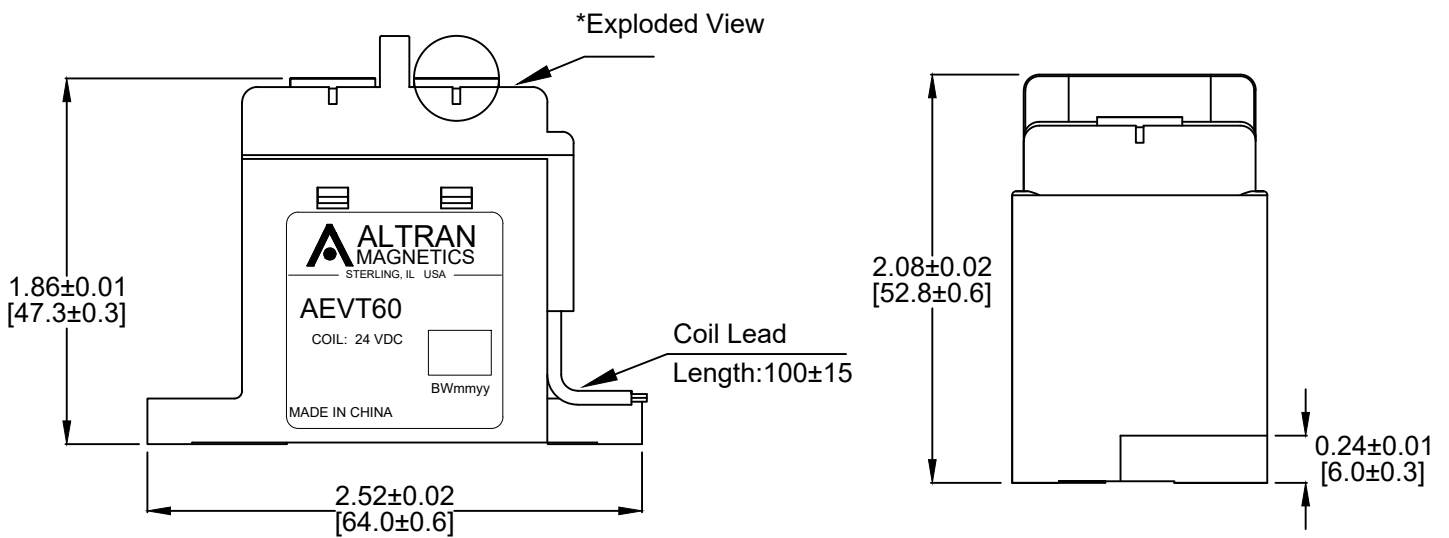
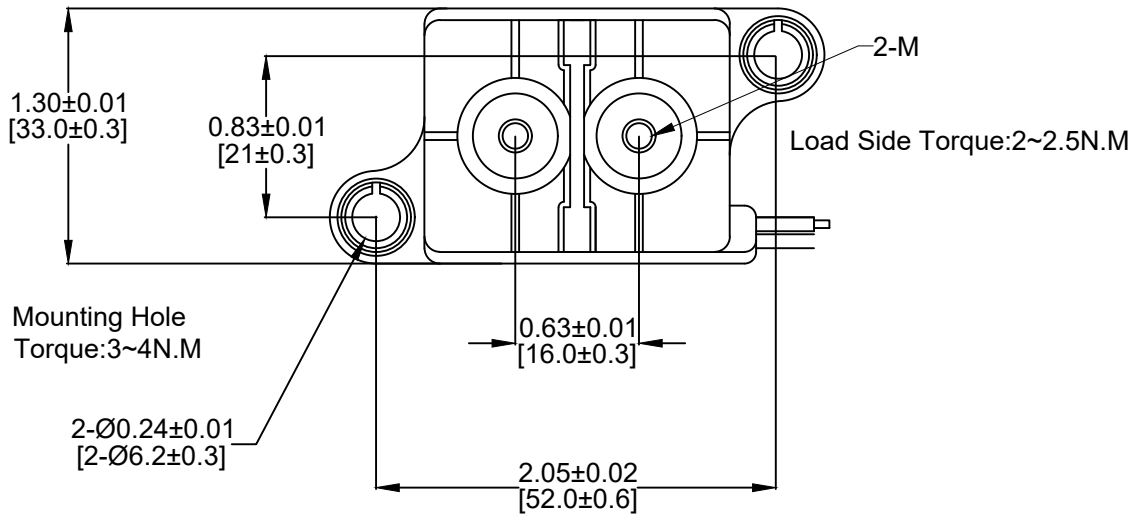

*Exploded View

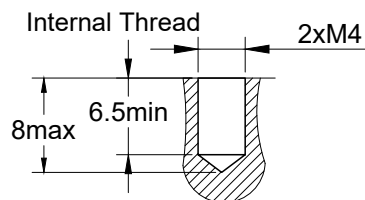

*Note: The wire size is 22AWG, diameter 1.5mm including insulation layer

Application Notes

1. Be sure to use split washers to prevent nuts from loosening, all the terminals or conductors must be in direct contact with the contactor's terminals. Nut tightening torque is specified below. Exceeding the maximum torque can lead to product failure.
 - Contact torque: 15.9 - 23.8 lb.in (1.8-2.7 N. m)
 - Mounting torque: 30 lb.in (3-4 N. m)
2. Load side marked with polarity of the product, please be sure to follow the product label for correct use. When the polarity of the load connection is reversed, the electrical characteristics promised in this specification cannot be guaranteed.
3. This is a product without circuit board. When the coil is turned off, the reverse electromotive force will appear. It is recommended to design a surge protection circuit to absorb the reverse electromotive force of the contactless coil.
4. Avoid installing in a strong magnetic field (close to a transformer or magnet), or near a heat source.
5. The coil and contact of the relay are continuously energized, and the power supply is cut off and immediately connected. At this time, the resistance of the coil will increase due to the increase of the temperature of the coil, so that the suction voltage of the product will increase, which may lead to the excess of the rated suction voltage. In this case, the following measures should be taken: reduce the load current; limit continuous power or use coil voltage higher than rated suction voltage.
6. When the voltage applied to both ends of the coil exceeds the maximum allowable applied voltage, the coil temperature may rise and lead to coil damage and inter-layer short circuit.
7. The rating in the contact parameters is the value at the time of the resistive load. When using an inductive load with $L/R > 1\text{ms}$, connect a surge current protection device in parallel with the inductive load. If no measures are taken, the electrical life may be degraded and the continuity may be poor. Please consider sufficient margin space in the design.
8. Coil drive power must be greater than coil power or it will reduce performance capability.
9. Please do not allow debris and oil to adhere to the main lead end; make sure that the external terminals are in reliable contact with the main outgoing end of the product, otherwise the temperature rise of the outgoing end may be too high due to the excessive contact resistance.
10. The lead wire connected with the high voltage end of the product must have the corresponding current load capacity and heat dissipation capacity (it is recommended to use a wire with min 6mm^2), to prevent overheating affecting the life of the contactor.
11. After the products with energy saving panel are connected to the power supply, the circuit will automatically switch about 100ms later. Please do not repeat the on-off operation during this period, or the energy saving panel of contactor may be damaged.
12. Do not use if dropped
13. It is impossible to determine all the performance parameters of relays in each specific application area. Therefore, customers should choose the products matching them according to their own conditions of use. If in doubt, contact Altran Magnetics.
14. Altran Magnetics reserves the right to make product changes. Customers should reconfirm the contents of the specification before first orders and ask for us to supply a new specification if necessary.