

Features

HIGH CURRENT CARRY AND HIGH VOLTAGE

Inert gas filled arc chamber suitable for high voltage switching

COMPACT STRUCTURE, LOW NOISE

Small, low-profile design with low noise while carrying or switching loads

SAFE FOR EXPLOSIVE ENVIRONMENTS

No arc leakage due to a hermetically sealed design

HIGH RELIABILITY DESIGN

Hermetic sealing creates a stable environment for high voltage switching

NO SPECIFIC MOUNTING ARRANGEMENT

Mountable in any orientation without reduction of performance

VARIOUS APPLICATIONS

Battery disconnect, EV charging, energy storage systems, photovoltaics, power control, circuit protection and much more

Sealing Type: Ceramic

- ✓ Dual Contactor
- ✓ Bi-Directional Switching available

Certification Information

1. Meet RoHS (2011/65/EU)
2. CE certified



Nomenclature

AEVT250D

B

N

Series code:

“AEVT250D” = AEVT250D

Coil Voltage Code:

“B” = 12VDC

Options (applied in this order):

Blank = Std. Options (Bottom Mount, Without Aux), Bidirectional
“N” = Non-Polar Load Terminals

High Voltage DC Contactor

AEVT250D Series

250A+/800VDC



Product Data Sheet

MAIN CONTACT

Contact Arrangement	TWO 1Form X (SPST-NO)	
Rated Operating Voltage	800 VDC	
Rated Current	250A	
Short Term Current (85°C) (70mm ² Busbar)	300A (20min)	
	500A (7.5min)	
	1500A (20s)	
	2000A (8.5s)	
Dielectric Withstanding Voltage (initial)	Between Open Contacts	2600VAC, ≤0.5mA, 1min
	Between Contacts to Coil	
Insulation Resistance (initial)	Terminal to Terminal	Min 1000mΩ@1000VDC
	Terminals to Coil	
Contact Voltage Drop (initial)	≤5mV@10A	
Breaking Limit	2000A@500VDC, 1 Cycles	

OPERATE / RELEASE TIME

Operate Time (includes bounce)	30ms, Max. @20°C
Release Time	10ms, Max @20°C

ENVIRONMENTAL DATA

Shock	Functional	196m/s ² Sine half-wave pulse
	Destructive	490m/s ² Sine half-wave pulse
Operating Temperature	-40 to +85 °C	
Humidity	5% to 85%RH	
Altitude	<5000m	
Vibration	10~2000Hz, 57.9 m/s ²	
Weight	1.38Lb (630g)	

Coil Data

Nominal Voltage	12VDC
(Max.) Pick-up Voltage (20°C)	9VDC
(Min.) Drop-out Voltage (20°C)	1VDC
Rated Coil Resistance ±7%	24Ω
Coil Power (20°C, Nominal Voltage)	6W*2

EXPECTED LIFE

Electrical Life 250A @ 800VDC	500 Cycles
Electrical Life 250A@500VDC	1,000 Cycles
Electrical Life 10A@500VDC	35,000 Cycles
Electrical Life 140A@20VDC	70,000 Cycles
Electrical Life 140A@50VDC	10,000 Cycles
Mechanical Life	200,000 Cycles

Current Carry Curve

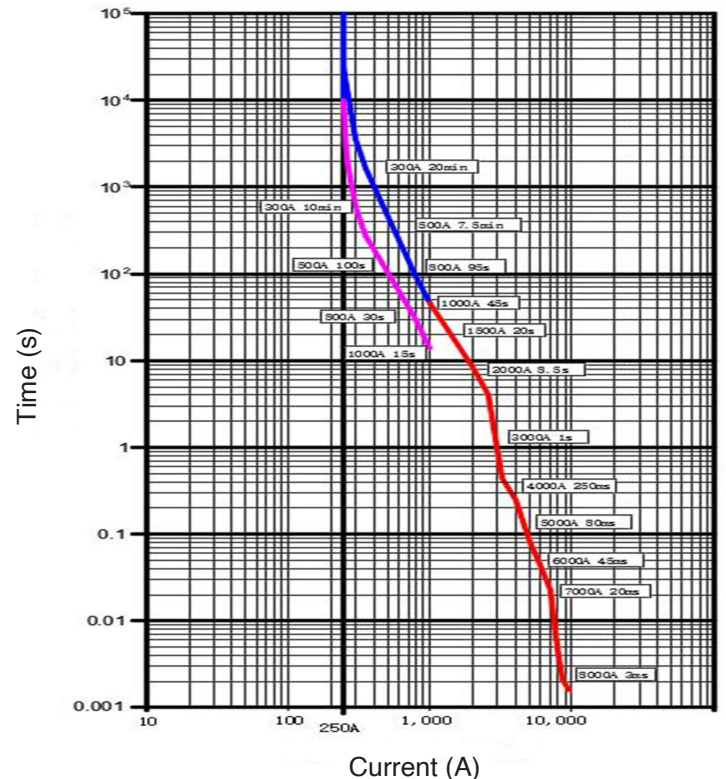

Outline Dimensions : inches (mm)

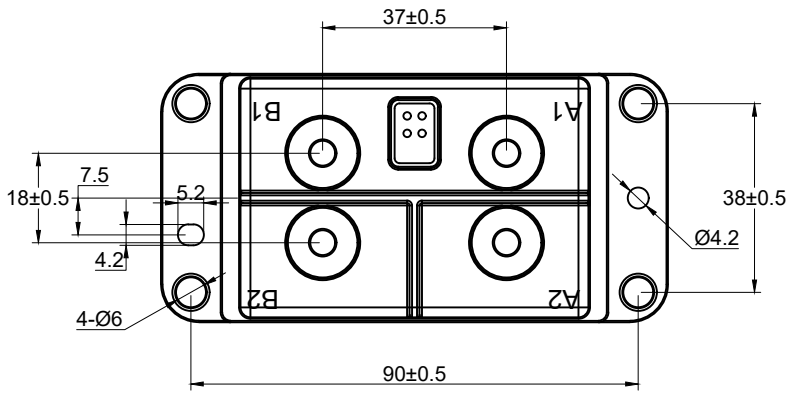
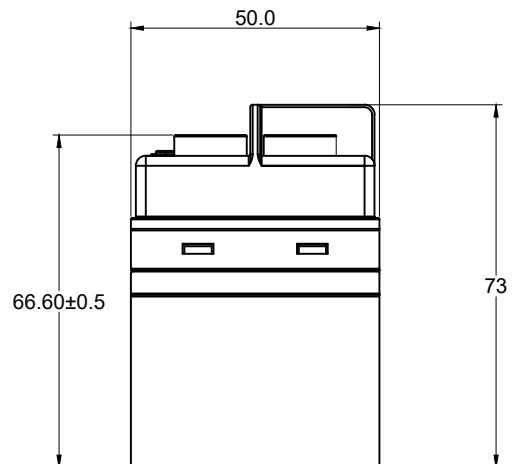
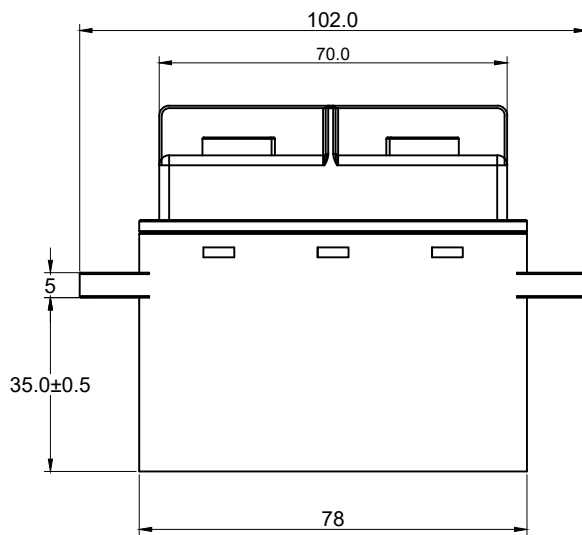
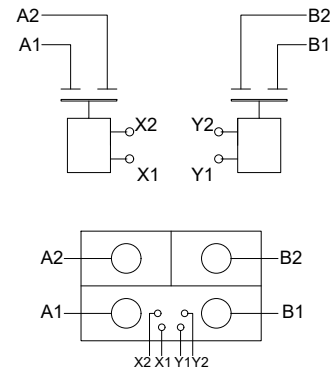

Diagram:



Application Notes

1. To prevent loosening, split washers should be used whenever the contactor is installed. All terminals or conductors must be in direct contact with the contactor's main terminals. Please control the tightening torque of each part within the specified range in the table below. If the torque exceeds the recommended range, it may cause damage to the sealed cavity and thread damage.
 - a. Static contact torque: 53.1 lb. in - 70.8 lb. in (6.0-8.0 N.m)
 - b. Installation torque: 26.5 lb. in - 35.4 lb. in (3.0-4.0 N.m)
2. Products with polarity marked on the load end must be used correctly according to the product label. When the load connection polarity is reversed, the electrical characteristics in this data sheet cannot be guaranteed.
3. It is necessary to design a surge-absorbing circuit to absorb the reverse electromotive force of the contactor coil. The use of diodes should be avoided. Diodes connected in parallel with coils will greatly prolong the release time of contactors, which may reduce the service life of products. Products with polarity marked on the load end must be used correctly according to the product marking. When the load connection polarity is reversed, the electrical characteristics promised in this manual cannot be guaranteed.
4. Avoid installing the contactor in a strong magnetic field environment (near transformers or magnets) and avoid placing the contactor near objects with heat radiation.
5. When continuous current is applied to the contacts of the relay, and the coil is turned on immediately after the power is cut off. At this time, as the temperature of the coil increases, the resistance of the coil will also increase, which will increase the pull-in voltage of the product, which may result in exceeding the rated pull-in voltage. In this case, the following measures should be taken to reduce the load current; limit the continuous power-on time or use a coil voltage higher than the rated pull-in voltage.
6. When the voltage applied to both ends of the coil exceeds the maximum allowable applied voltage, the coil temperature may rise and lead to coil damage and inter-layer short circuit.
7. The rating in the contact parameters is the value at the time of the resistive load. When using an inductive load with $L/R > 1\text{ms}$, connect a surge current protection device in parallel with the inductive load. If no measures are taken, the electrical life may be degraded and the continuity may be poor. Please consider sufficient margin space in the design.
8. Coil drive power must be greater than coil power or it will reduce performance capability.
9. Please do not allow debris and oil to adhere to the main terminals; Make sure that the main terminals are in reliable contact with the load conductor, otherwise the temperature rise of the terminal/conductor connection may be too high due to the excessive contact resistance.
10. The load conductor must have the corresponding current load capacity and heat dissipation capacity (it is recommended to use wire with min 4mm²), to prevent overheating and affecting the life of the contactor.
11. Do not use if dropped.
12. It is impossible to determine all the performance parameters of contactors in each specific application, therefore, customers should choose the products matching them according to their own conditions of use. If in doubt, contact Altran. The customer will be responsible for validating that the products meet their application.
13. Altran reserves the right to make changes as needed. Customers should reconfirm the contents of the specification or ask for us to supply a new specification if necessary.