

Features

HIGH CURRENT CARRY AND HIGH VOLTAGE

Inert gas filled arc chamber suitable for high voltage switching

COMPACT STRUCTURE, LOW NOISE

Small, low-profile design with low noise while carrying or switching loads

SAFE FOR EXPLOSIVE ENVIRONMENTS

No arc leakage due to a hermetically sealed design

HIGH RELIABILITY DESIGN

Hermetic sealing creates a stable environment for high voltage switching

NO SPECIFIC MOUNTING ARRANGEMENT

Mountable in any orientation without reduction of performance

VARIOUS APPLICATIONS

Battery disconnect, EV charging, energy storage systems, photovoltaics, power control, circuit protection and much more

Sealing Type: Ceramic

- ✓ Bottom mount/side mount options available
- ✓ Bi-directional



Certification Information

1. Meet RoHS (2011/65/EU)
2. CE certified

Nomenclature

AEVE250

B

-

Series code:

“AEVE250” = AEVE250

Coil Voltage Code:

“B” = 12VDC

“C” = 24VDC

Options (applied in this order):

Blank = Std. Options (Bottom Mount, Without Aux)

“S” = Side Mount Version

Product Data Sheet

MAIN CONTACT

Contact Arrangement	1 Form A (SPST-NO)	
Rated Operating Voltage	1000VDC	
Rated Current	250A @ 450VDC	
Short Term Current (85°C) (60mm ² Busbar)	500A (2min)	
Dielectric Withstanding Voltage (initial)	Between Open Contacts	3000VDC, 1mA, 1min
	Between Contacts to Coil	2500VAC, 1mA, 1min
Insulation Resistance (initial)	Terminal to Terminal	Min. 1000 MΩ@1000VDC (Initial) Min 50MΩ @500VDC (After durability test)
	Terminals to Coil	
Short Circuit Current	20,000A (3ms) (No fire or explosion)	
Contact Voltage Drop (initial)	Max.125mV (250A)	
Breaking Limit	2000A @ 500 VDC, 1 Cycle	

EXPECTED LIFE

Electrical Life (Make Only) 140A @ 20VDC	75,000 Cycles
Electrical Life (Break Only) 250A @ 450VDC	1,000 Cycles
Electrical Life (Break Only) 2000A @ 500VDC	1 Cycle
Mechanical Life	200,000 Cycles

OPERATE / RELEASE TIME

Operate Time (includes bounce)	30ms, Max. @20°C
Release Time	10ms, Max @20°C

ENVIRONMENTAL DATA

Shock	Functional	196m/s ² Sine half-wave pulse
	Destructive	490m/s ² Sine half-wave pulse
Operating Temperature	-40 to +85 °C	
Humidity	5% to 85%RH	
Weight	0.88Lb (0.4kg)	

COIL DATA

Nominal Voltage	12VDC	24VDC
Max. Pick-up Voltage (20°C)	9VDC	18VDC
Min. Drop-out Voltage (20°C)	0.5VDC	1VDC
Max. Inrush Current (20°C)	6W	6W
Average Holding Current (20°C)	24 Ω	96 Ω

Electrical Endurance

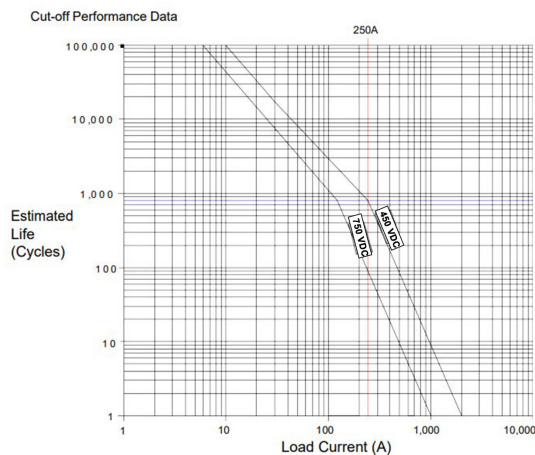

Outline Dimensions: (mm)
• Bottom Mount

Current Carry vs. Time Performance

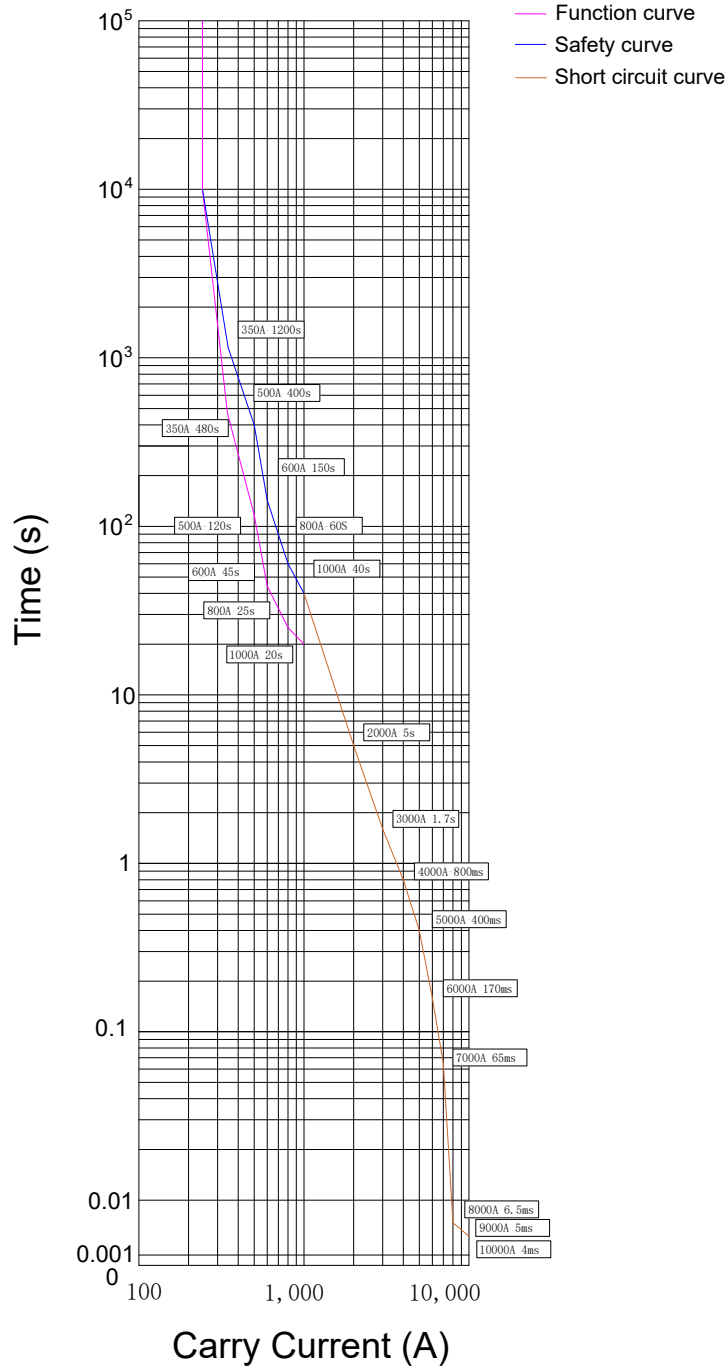

Outline Dimensions : inches (mm)

Bottom Mount

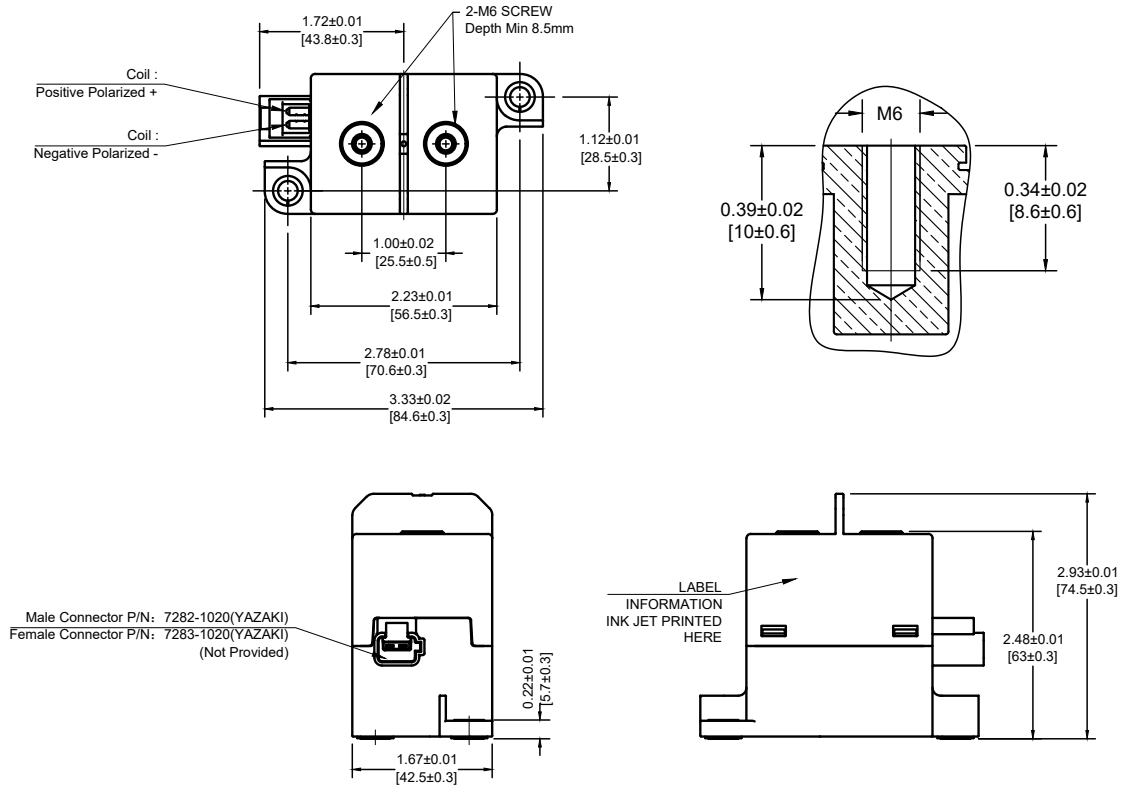

Side Mount

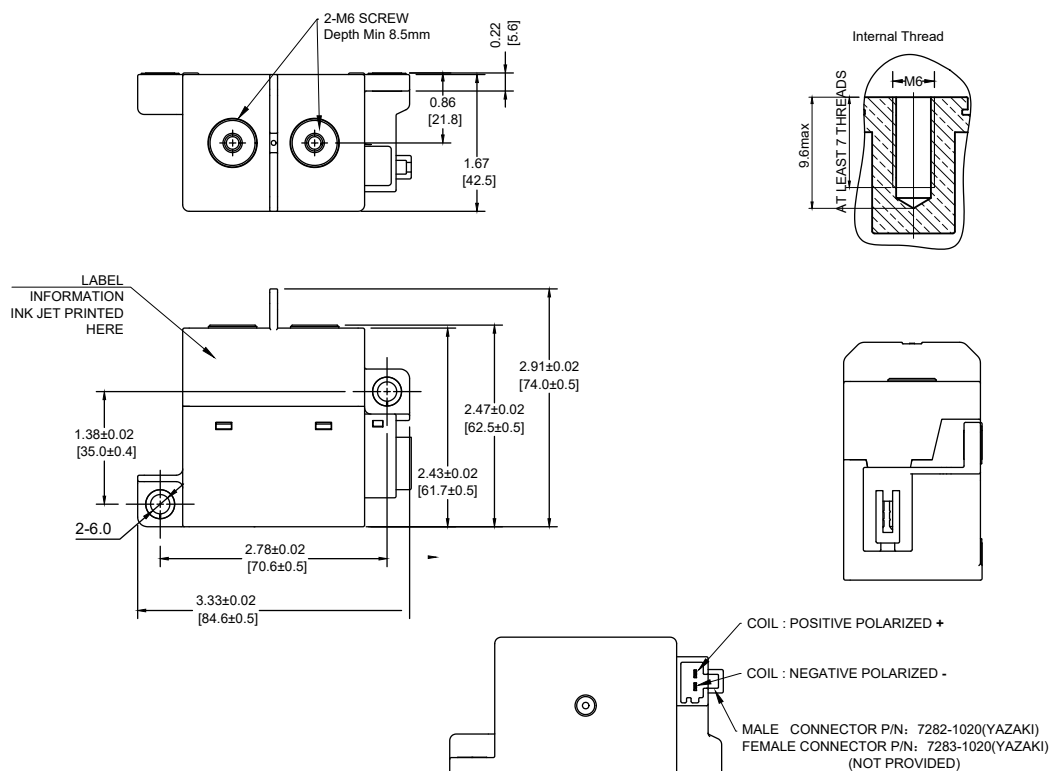

Application Notes

1. To prevent loosening, split washers should be used whenever the contactor is installed. All terminals or conductors must be in direct contact with the contactor's main terminals. Please control the tightening torque of each part within the specified range in the table below. If the torque exceeds the recommended range, it may cause damage to the sealed cavity and thread damage.
 - Static contact torque: 53.1 lb. in - 70.8 lb. in (6.0-8.0 N.m)
 - Installation torque: 26.5 lb. in - 35.4 lb. in (3.0-4.0 N.m)
2. Products with polarity marked on the load end must be used correctly according to the product label. When the load connection polarity is reversed, the electrical characteristics in this data sheet cannot be guaranteed.
3. It is necessary to design a surge absorbing circuit to absorb the reverse electromotive force of contactor coil. Use of diodes should be avoided. Diodes connected in parallel with coils will greatly prolong the release time of contactors, which may reduce the service life of products. Products with polarity marked on the load end must be used correctly according to the product marking. When the load connection polarity is reversed, the electrical characteristics promised in this manual cannot be guaranteed.
4. Avoid installing the contactor in a strong magnetic field environment (near transformers or magnets) and avoid placing the contactor near objects with heat radiation.
5. When continuous current is applied to the contacts of the relay, and the coil is turned on immediately after the power is cut off. At this time, as the temperature of the coil increases, the resistance of the coil will also increase, which will increase the pull-in voltage of the product, which may result in exceeding the rated pull-in voltage. In this case, the following measures should be taken to reduce the load current; limit the continuous power-on time or use a coil voltage higher than the rated pull-in voltage.
6. When the voltage applied to both ends of the coil exceeds the maximum allowable applied voltage, the coil temperature may rise and lead to coil damage and inter-layer short circuit.
7. The rating in the contact parameters is the value at the time of the resistive load. When using an inductive load with $L/R > 1\text{ms}$, connect a surge current protection device in parallel with the inductive load. If no measures are taken, the electrical life may be degraded and the continuity may be poor. Please consider sufficient margin space in the design.
8. Coil drive power must be greater than coil power or it will reduce performance capability.
9. Please do not allow debris and oil to adhere to the main terminals; Make sure that the main terminals are in reliable contact with the load conductor, otherwise the temperature rise of the terminal / conductor connection may be too high due to the excessive contact resistance.
10. The load conductor must have the corresponding current load capacity and heat dissipation capacity (it is recommended to use wire with min 4mm²), to prevent overheating and affecting the life of the contactor.
11. Do not use if dropped.
12. It is impossible to determine all the performance parameters of contactors in each specific application, therefore, customers should choose the products matching them according to their own conditions of use. In doubt, contact Altran. The customer will be responsible for validating that the products meet their application.
13. Altran reserves the right to make changes as needed. Customers should reconfirm the contents of the specification or ask for us to supply a new specification if necessary.