

## Features

### HIGH CURRENT CARRY AND HIGH VOLTAGE

Inert gas filled arc chamber suitable for high voltage switching

### COMPACT STRUCTURE, LOW NOISE

Small, low-profile design with low noise while carrying or switching loads

### SAFE FOR EXPLOSIVE ENVIRONMENTS

No arc leakage due to a hermetically sealed design

### HIGH RELIABILITY DESIGN

Hermetic sealing creates a stable environment for high voltage switching

### NO SPECIFIC MOUNTING ARRANGEMENT

Mountable in any orientation without reduction of performance

### VARIOUS APPLICATIONS

Battery disconnect, EV charging, energy storage systems, photovoltaics, power control, circuit protection and much more

## Sealing Type: Ceramic



## Certification Information

1. Meet RoHS (2011/65/EU)
2. CE certified

## Nomenclature

AEVT200

B

-

### Series code:

“AEVT200” = AEVT200 Series

### Coil Voltage Code:

“B” = 12VDC

“C” = 24VDC

### Options (applied in this order):

Blank = Std. Options (Bottom Mount Size: 64.5x27, Coil Wires, Without Aux. Contact & Polarized Load Terminals)

S=Side Mount

01=Bottom mounting size 63.6×26;

L= Bottom Mount & wires lead, mounting size 63.6×26

**Product Data Sheet**

**MAIN CONTACT**

Contact Arrangement	1 Form X (SPST-NO)	
Rated Operating Voltage	750 VDC	
Rated current	200A @450VDC	
Max. Short Term Current	2,500A (1s)	
Short Term Current	300A (10min)	
Dielectric Withstanding Voltage (initial)	Between Open Contacts	5,000VDC 1mA 1min
	Between Contacts to Coil	2,500VAC, 1mA 1min
Insulation Resistance (initial)	Terminal to Terminal	Min. 1000 M Ω@1000 VDC
	Terminals to Coil	
Contact Voltage Drop (initial)	≤10mΩ (1A 6V)	
Limit Breaking	1750A@450VDC, 1 Cycle	

**OPERATE / RELEASE TIME**

Operate Time	30ms, Max @20°C
Release Time	10ms, Max @20°C

**ENVIRONMENTAL DATA**

Shock	Functional	196m/s <sup>2</sup> Sine half-wave pulse
	Destructive	490m/s <sup>2</sup> Sine half-wave pulse
Operating Temperature	-40 to +85°C	
Humidity	5% to 85%RH	
Weight	0.84Lb (0.38kg)	

**EXPECTED LIFE**

Electrical Endurance (Make/Break) 200A@450VDC	5,000 Cycles
Electrical Endurance (Make/Break) 200A@650VDC	2000 Cycles
Mechanical Life	200,000 Cycles

**COIL DATA**

Nominal Voltage	12VDC	24VDC
Max. Pick-up Voltage (20°C)	9VDC	18VDC
Min. Drop-out Voltage (20°C)	1VDC	2.0VDC
Coil Power 20°C at Nominal Voltage	6W	6W
Rated Coil Resistance±10% (20°C)	24 Ω	96 Ω

**Current Carry Curve**

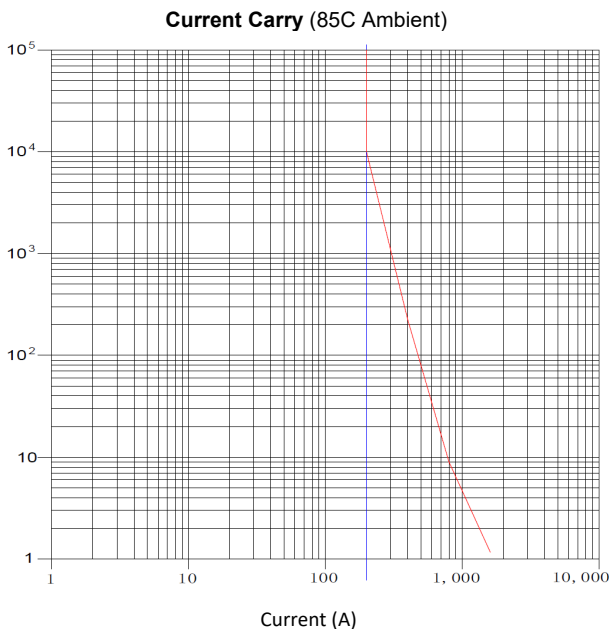

Note:

1. Do not meet dielectric & IR after the test.
2. ON:OFF= 1s:9s.
3. The ambient environment of application should not cause any dewing or icing inside the relay. Otherwise, the relay may fail to work.

**Outline Dimensions : (mm)**

**Side Mount "AEVT200-BS"**

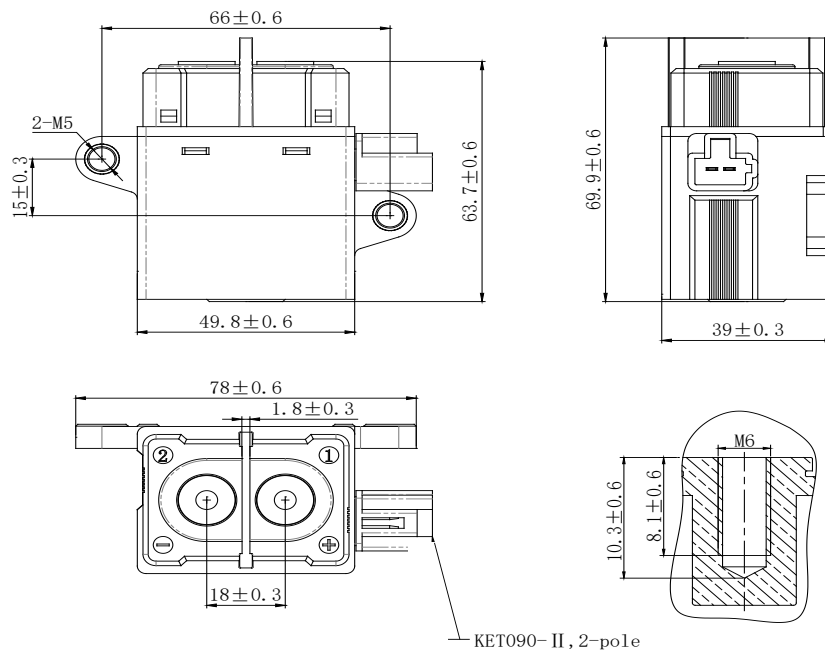

**Bottom Mount 1. "AEVT200-B"**

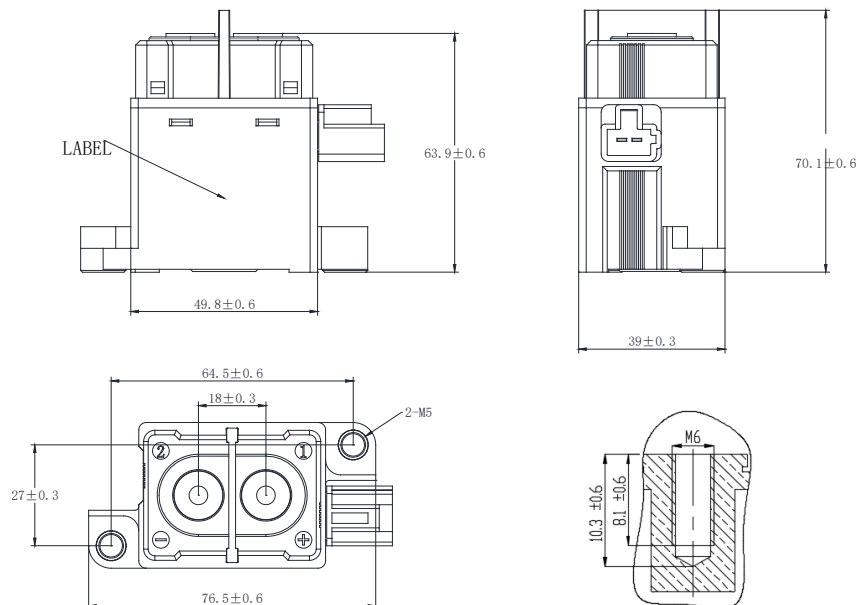

\*Note: The wire size is 20AWG-22AWG, diameter 1.5mm including insulation layer

**Bottom Mount 2. "AEVT200-B-01"**

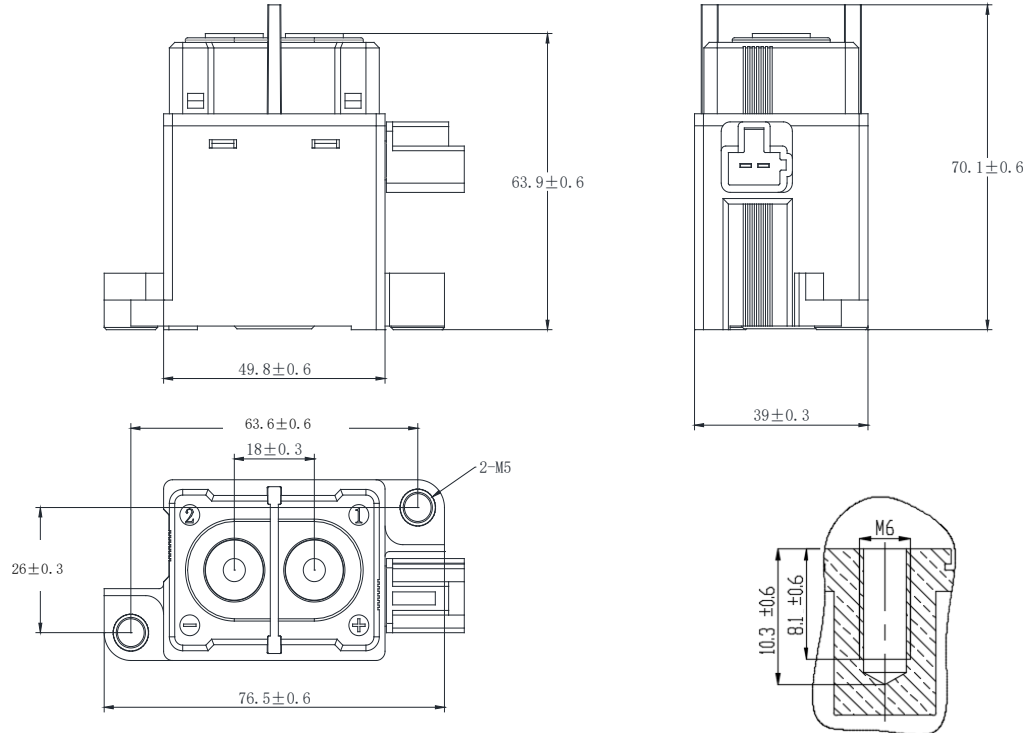

**Bottom Mount & Wires Lead**

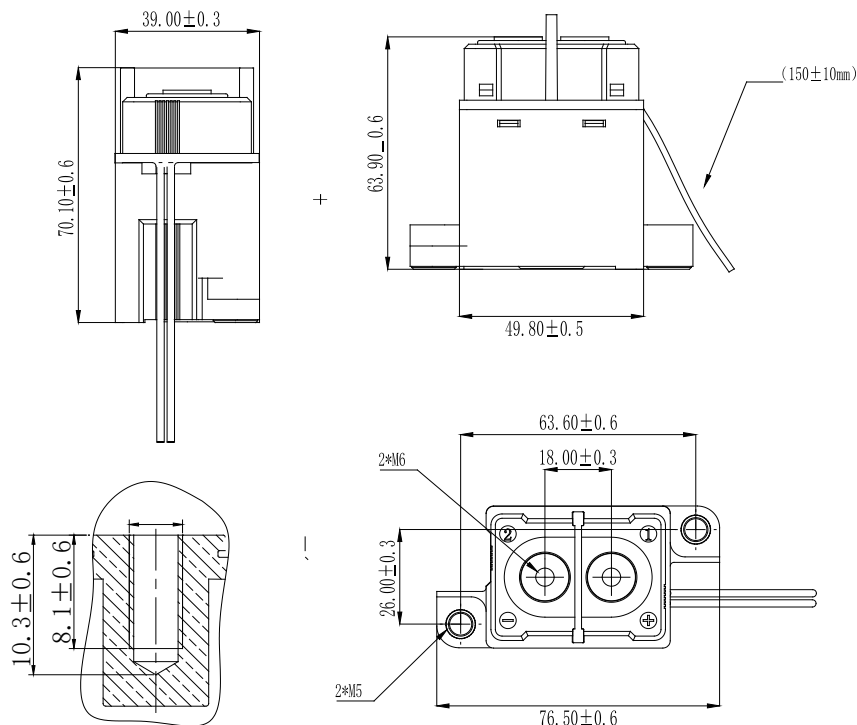

\*Note: The wire size is 20AWG-22AWG, diameter 1.5mm including insulation layer

## Application Notes

1. Be sure to use split washers to prevent nuts from loosening, all the terminals or conductors must be in direct contact with the contactor's terminals. Nut tightening torque is specified below. Exceeding the maximum torque can lead to product failure.
  - Contact torque: 53.1 lb. in - 70.8 lb. in (6.0-8.0 N.m)
  - Mounting torque: 26.5 lb. in - 35.4 lb. in (3.0-4.0 N.m)
2. Load side marked with polarity of the product, please be sure to follow the product label for correct use. When the polarity of the load connection is reversed, the electrical characteristics in this data sheet cannot be guaranteed.
3. This is a product without circuit board. When the coil is turned off, the reverse electromotive force will appear. It is recommended to design a surge protection circuit to absorb the reverse electromotive force of the contact-less coil.
4. Avoid installing in a strong magnetic field (close to a transformer or magnet), or near a heat source.
5. The coil and contact of the relay are continuously energized, and the power supply is cut off and immediately connected. At this time, the resistance of the coil will increase due to the increase of the temperature of the coil, so that the suction voltage of the product will increase, which may lead to the excess of the rated suction voltage. In this case, the following measures should be taken: reduce the load current; limit continuous power or use coil voltage higher than rated suction voltage.
6. When the voltage applied to both ends of the coil exceeds the maximum allowable applied voltage, the coil temperature may rise and lead to coil damage and inter-layer short circuit.
7. The rating in the contact parameters is the value at the time of the resistive load. When using an inductive load with  $L/R > 1\text{ms}$ , connect a surge current protection device in parallel with the inductive load. If no measures are taken, the electrical life may be degraded and the continuity may be poor. Please consider sufficient margin space in the design.
8. Coil drive power must be greater than coil power or it will reduce performance capability.
9. Please do not allow debris and oil to adhere to the main lead end; make sure that the external terminals are in reliable contact with the main outgoing end of the product, otherwise the temperature rise of the outgoing end may be too high due to the excessive contact resistance.
10. The lead wire connected with the high voltage end of the product must have the corresponding current load capacity and heat dissipation capacity (it is recommended to use a copper bar with a considerable section area), to prevent overheating affecting the life of the contactor.
11. Do not use if dropped.
12. It is impossible to determine all the performance parameters of relays in each specific application area, Therefore, customers should choose the products matching them according to their own conditions of use. If in doubt, contact Altran Magnetics. The customer will be responsible for validating that the products meet their application.
13. Altran Magnetics reserves the right to make product changes. Customers should reconfirm the contents of the specification before first orders and ask for us to supply a new specification if necessary.