

Features

HIGH CURRENT CARRY AND HIGH VOLTAGE

Inert gas filled arc chamber suitable for high voltage switching

COMPACT STRUCTURE, LOW NOISE

Small, low-profile design with low noise while carrying or switching loads

COIL ECONOMIZER

Economized coil for low power consumption

SAFE FOR EXPLOSIVE ENVIRONMENTS

No arc leakage due to a hermetically sealed design

HIGH RELIABILITY DESIGN

Hermetic sealing creates a stable environment for high voltage switching

NO SPECIFIC MOUNTING ARRANGEMENT

Mountable in any orientation without reduction of performance

VARIOUS APPLICATIONS

Battery disconnect, EV charging, energy storage systems, photovoltaics, power control, circuit protection and much more

Sealing Type: Epoxy/Resin

- ✓ Bidirectional switching option



Certification Information

1. Meet RoHS (2011/65/EU)
2. CE certified
3. UL Approved

Nomenclature

AEV150

M

-

Series code:
"AEV150" = AEV150

Coil Voltage Code:
"M" = 12-24 VDC

Options (applied in this order):
Blank = Std. Options (Bottom Mount, Without Aux. Contact & Polarized Load Terminals)
"A" = With Aux. Contact (SPST-NO)
"N" = Non-Polar Load Terminals

Product Data Sheet

MAIN CONTACT

Contact Arrangement	1 Form X (SPST-NO)	
Rated Operating Voltage	12-900VDC	
Continuous (Carry) Current	150A -200A (65 °C)	
Make/Break Current	See chart below	
Max Short Circuit Current	2,000A @320VDC, 1 cycle *1	
Dielectric Withstanding Voltage (initial)	Between Open Contacts	2,200Vrms, ≤1mA
	Between Contacts to Coil	2,200 Vrms, ≤1mA
Insulation Resistance (initial)	Terminal to Terminal	New: Min 100 MΩ@500VDC End of life: Min 50 MΩ @500VDC
	Terminals to Coil	
Voltage Drop (@150A)	≤60mV	

OPERATE / RELEASE TIME

Close (includes bounce)	25ms, Max.
Bounce (after close only)	7ms, Max.
Release (@2000A includes arc)	12ms, Max.

ENVIRONMENTAL DATA

Shock	Functional	196m/s ² Sine half-wave pulse
	Destructive	490m/s ² Sine half-wave pulse
Operating Temperature	-40 to +85 °C	
Altitude	<4000m	
Weight	0.95 Lb (0.43 kg)	

EXPECTED LIFE

Resistive load life	See chart below
Mechanical life	200,000 cycles

COIL DATA

Nominal Voltage	12/24 VDC
(Max.) Voltage	36VDC
(Max.) Pick-up Voltage	9VDC
(Min.) Hold Voltage	7.5VDC
(Min.) Drop-out Voltage	6VDC
Max. Inrush Current	3.8A
Average Holding Current	0.13A@12VDC / 0.07A@24VDC

Current Carry Curve

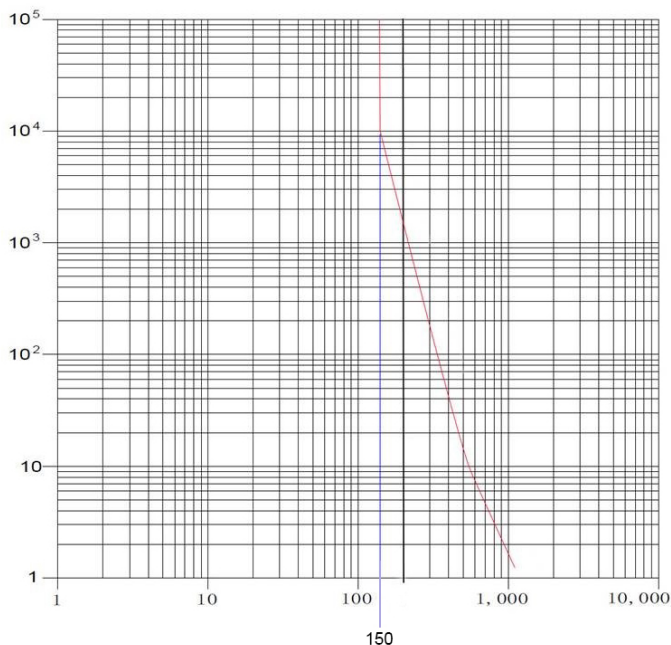

AUX. CONTACT

Aux. Contact Arrangement	1 Form A
Aux. Contact/Current Max.	2A@30VDC/3A@125VAC
Aux. Contact Current Min.	100mA@8V
Aux. Contact Resistance Max.	0.417ohms@30VDC/ 0.150ohms@125VAC

Estimated Make & Break Resistive Load Ratings

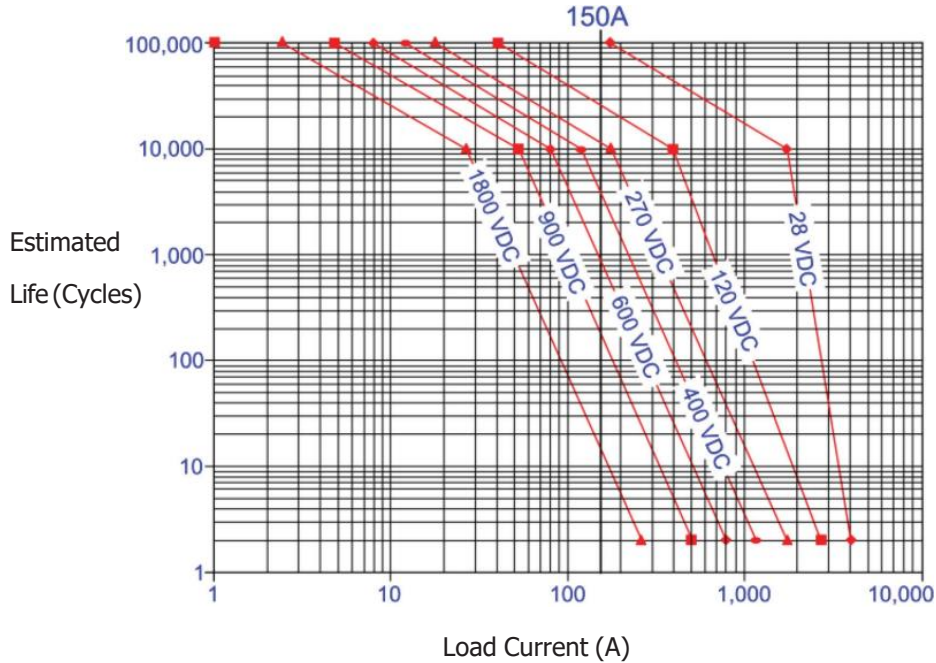

Note:

1. For resistive loads with 300uH maximum inductance.
2. The maximum make current is 650A to avoid contact welding.
3. Estimates based on extrapolated data. User to confirm performance in application.

Electrical Load Life Ratings for Typical AEV Applications

MAKE/BREAK LIFE CAPACITIVE & RESISTIVE LOADS AT 320VDC *1

@90% pre-charge (make only), see chart below 50,000 cycles
 @Min 80% pre-charge (make only), see chart below 50 cycles

Note:

*1: Resistive load includes L=25uH. Load @2500A, test @200uH

AEV150 Capacitive Make Test Curves for Pre-Charged Motor Controller

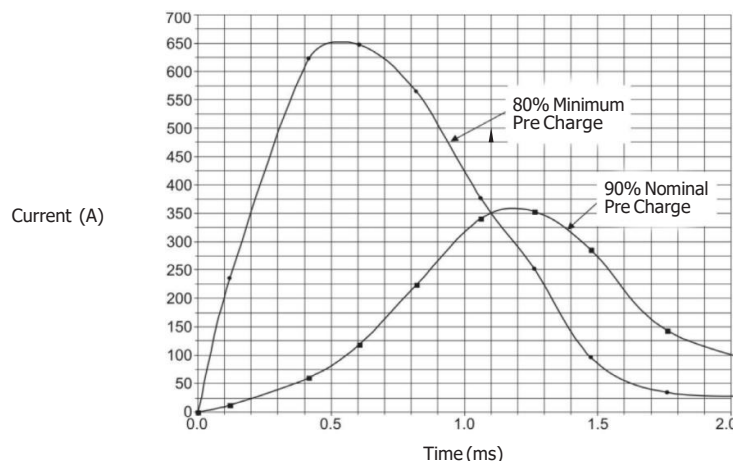

Outline Dimensions : inches (mm)

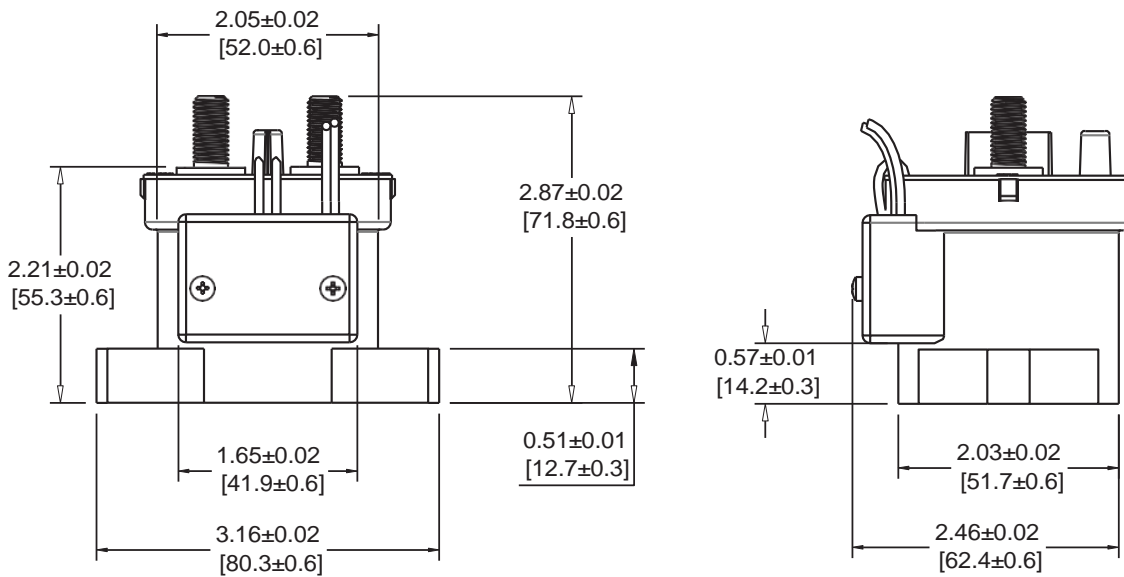
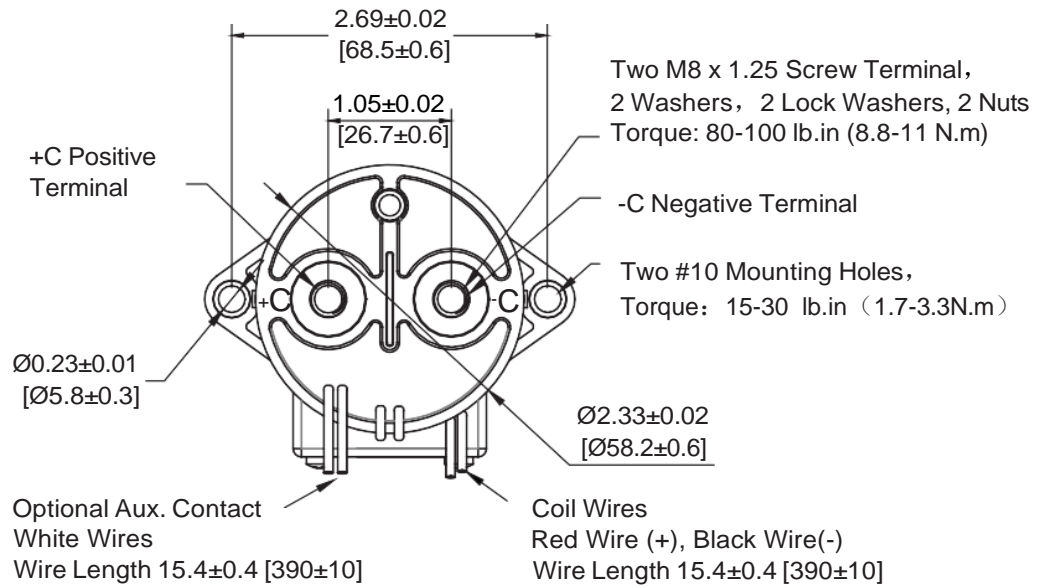

*Note: The wire size is 22 AWG.

Application Notes

1. Be sure to use split washers to prevent nuts loosening. Nut tightening torque range is specified as below. Exceeding the maximum torque can lead to product failure.
 - Contact torque (M8): 80 - 100 lb.in (8.8 - 11 N.m)
 - Mounting torque: 15 - 30 lb.in (1.7 - 3.3 N.m)
2. Contact Terminals are polarized so refer to drawing during connection. There is a reverse surge absorption circuit so that it is not necessary to use a surge protective device.
3. Do not use if dropped.
4. Avoid installing in a strong magnetic field (close to a transformer or magnet), or near a heat source.
5. Electrical life:
Use per load capability and life cycle limits so as not to cause a failure. (treat the contactor as a product with specified life and replace it when necessary). It is possible to make parts burn around the contactor once operating failure occurs. It is necessary to take layout considerations into account and to make sure power shall be cut off within 1 second.
6. Lifetime of internal gas diffusion:
The contactor is sealed and filled with gas, lifetime of gas diffusion is determined by temperature in contact chamber (ambient temperature + temperature generated by contact operation). Operate only in an ambient temperature from -40 to +85 °C.
7. If inductive load ($L/R > 1\text{ms}$) is used then a surge current protection device should be connected in parallel to the inductive load.
8. Drive power must be greater than coil power or it will reduce performance capability.
9. Unit operates after power applied for 0.1s, do not rapidly switch unit.
10. Avoid debris or oil contamination of the main terminals to optimize contact and avoid excess heat generation.